

# An Introduction to the Design of Industrial Ventilation Systems

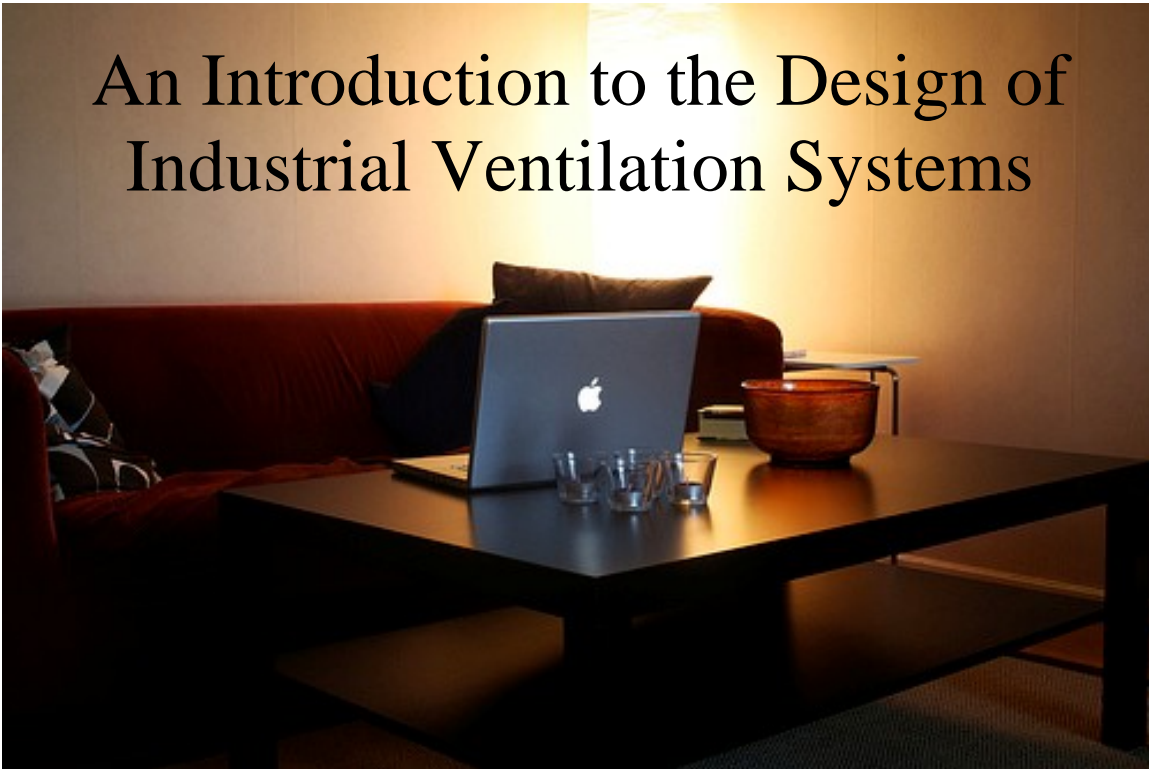

---

# An Introduction to the Design of Industrial Ventilation Systems

By

J. Paul Guyer, P.E., R.A.

PDHLibrary Course No 0005462  
2 PDH HOURS

---

# An Introduction to Design of Industrial Ventilation System



**Guyer Partners**  
44240 Clubhouse Drive  
El Macero, CA 95618  
(530)7758-6637  
jpguyer@pacbell.net

## J. Paul Guyer, P.E., R.A.

Paul Guyer is a registered civil engineer, mechanical engineer, fire protection engineer, and architect with over 35 years experience in the design of buildings and related infrastructure. For an additional 9 years he was a senior-level advisor to the California Legislature. He is a graduate of Stanford University and has held numerous national, state and local positions with the American Society of Civil Engineers and National Society of Professional Engineers.

# **CONTENTS**

## **1. INTRODUCTION**

- 1.1 GENERAL CRITERIA
- 1.2 DESIGN PROCEDURE
- 1.3 DESIGN CRITERIA
- 1.4 CONTROLS
- 1.5 OPERATIONAL CONSIDERATIONS
- 1.6 COMMISSIONING

## **2. WOOD SHOP FACILITIES**

- 2.1 FUNCTION
- 2.2 OPERATIONAL CONSIDERATIONS
- 2.3 FLOOR PLAN LAYOUT
- 2.4 DESIGN CRITERIA
- 2.5 SAFETY AND HEALTH CONSIDERATIONS

## **3. PAINT SPRAY BOOTHS**

- 3.1 FUNCTION
- 3.2 OPERATIONAL CONSIDERATIONS
- 3.3 DESIGN CRITERIA
- 3.4 FANS AND MOTORS
- 3.5 REPLACEMENT AIR
- 3.6 SYSTEM CONTROLS
- 3.7 RESPIRATORY PROTECTION

## 1. INTRODUCTION

This is a general introduction to the design of industrial ventilation systems, with an additional discussion of two of the more common industrial ventilation applications: wood shops and paint spray booths.

**1.1 GENERAL CRITERIA.** Installing engineering controls is the preferred method of controlling hazardous processes as specified in 29 CFR (Code of Federal Regulations) 1910.1000(e), *Air Contaminants*. Properly designed industrial ventilation systems are the most common form of engineering controls.

**1.2 DESIGN PROCEDURE.** Refer to the ACGIH (American Conference of Governmental Industrial Hygienists) IV Manual, *Industrial Ventilation; A Manual of Recommended Practice*, for system design calculations. Design all industrial ventilation systems in accordance with the paragraphs below.

- **Step 1.** Identify all significant contaminant sources that require ventilation control. Request the local industrial hygiene office to provide a source characterization with area diagrams of the contaminant sources, and employee work areas. Also, consider how the system being designed might affect the performance of any existing processes, industrial ventilation systems or HVAC systems.
- **Step 2.** Consider how the facility is to be used or expanded in the future. It may be possible to initially specify fans that are capable of handling future needs at minimal increased cost.
- **Step 3.** Select or design the exhaust hood that best suits the work piece or operation. Design the exhaust hood to enclose the work piece or operation as much as possible. This will reduce the ventilation rates required to provide contaminant control. This UFC provides optimum exhaust hood designs for many of the operations covered.
- **Step 4.** Determine the capture velocity required to control generated contaminants. Capture velocities are specified assuming there are no cross drafts or turbulence that adversely affects the capture efficiency. Reduce potential for cross drafts or turbulence near a given exhaust hood by properly locating and designing the hood with baffles, and also by designing the replacement air system to complement the exhaust system.
- **Step 5.** Determine the exhaust volumetric flow, in cubic feet per minute (cfm), required to maintain the capture velocity determined in paragraph
- **Step 6.** Create a line drawing of the proposed system. Include plan and elevation dimensions, fan location and air cleaning device location. Identify each hood, branch duct and main duct sections.

- **Step 7.** Size ductwork using the balance by design or the blast gate method. Maintain the required minimum transport velocity throughout the system.
- **Step 8.** Determine requirements for replacement air. Based on the process, determine if the room should be under slightly negative, neutral or slightly positive pressure with respect to the surrounding area. The surrounding area can be either outside the building envelope or an adjacent room or hallway. Determine if tempered replacement air is needed.

**1.3 DESIGN CRITERIA.** Several design criteria are common to all industrial ventilation systems; use the ACGIH IV Manual for primary guidance. See paragraphs below for additional guidance.

**1.3.1 Ductwork.** In addition to the recommendations of the ACGIH IV Manual, consider the following when designing a ventilation system.

- Specify duct gage, reinforcement schedule and hanger design and spacing, in accordance with SMACNA RIDCS, Round Industrial Duct Construction Standards for round duct and SMACNA (Sheet Metal and Air Conditioning Contractors' National Association) RTIDCS, Rectangular Duct Construction Standards for rectangular duct.
- Install clean-out doors in ductwork that conveys particulate material such as wood dust or blasting grit. Mount clean-out doors on top half of horizontal runs near elbows, junctions, and vertical runs.

### **1.3.2 Fans**

**1.3.2.1 Selection.** Except where specified below, fan selection criteria for replacement air fans and exhaust air fans are identical.

- Select exhaust system industrial fans that meet design pressure and volume flow rate requirements and have the AMCA (Air Movement and Control Association)-certified performance seal. The design pressure requirement must account for

any system effects caused by non-uniform airflow into or out of the fan. See AMCA 201, Fans and Systems for more information on system effects. Specify a fan class that is appropriate for the design operating point. Do not select fans with forward curved blades.

- When selecting fan capacity, consider if the process room pressure will be positive, negative or neutral with respect to the external areas. Select a fan that will provide the necessary volumetric flow rate to maintain the desired process room pressure. Ensure that all sources of exhaust air are considered when selecting fan capacity.
- Specify fan shafts that have a uniform diameter along the entire length. Use bearings that are rated with an average life of 200,000 hours.
- Select only energy efficient motors. Select the motor to handle cold startup amperage for nonstandard air processes.
- Specify vibration-isolating couplings at the fan inlet and outlet. Mount all fans on vibration isolating bases.
- If the planner's forecasts change in the processes to occur within the next couple of years, which would require an increase in the amount of replacement or exhaust air, then consider purchasing a larger capacity fan and oversized wiring.

**1.3.2.2 Location.** Locate the exhaust fan after the air pollution control equipment to protect fan blades from contaminated air-stream. Provide access for maintenance to all fans, including ladders and guardrails where necessary. Refer to NFPA 70, National Electrical Code for motor controller and disconnect location requirements. In all cases, install exhaust fans outside the building that they serve. Installing the fan outside the building envelope will isolate the working space from contaminants during fan maintenance, minimize noise inside the building, and ensure that ductwork within the building envelope is under negative pressure.

### 1.3.3 Exhaust Stacks

- **Design Considerations.** Refer to the ACGIH IV Manual for exhaust stack design criteria. The best designs are cylindrical, vertical discharge stacks as shown in Figure 1-1. The best protection from rain, when the ventilation system is not

running, is the “offset stack” design C, as shown in Figure 1-1. Water may still enter the system with straight stack design A. Provide a means to drain water from the fan housing.

- **Location and Structural Considerations.** Refer to ASHRAE (American Society of Heating, Refrigeration and Air Conditioning Engineers) Handbook, Fundamentals for information on airflow around buildings. Do not select stack locations based on prevailing winds. A stack must provide effluent dispersion under all wind conditions. Refer to UFC 1-200-01, Design: General Requirements for exhaust stack structural design considerations. Some structural considerations are wind load, lightning protection, and stack support. Refer to and SMACNA GSSDC, Guide for Steel Stack Design and Construction for additional information.

**1.3.3 Air Pollution Control Equipment.** Requirements for air pollution equipment vary by process and geographical region in the United States. Contact the local environmental manager to determine the pollution control requirements for the process.

**1.3.4 Replacement Air.** Replacement air is as important as exhaust air in controlling industrial process contaminants. Properly designed replacement air will (1) ensure that exhaust hoods have enough air to operate properly, (2) help to eliminate cross-drafts through window and doors, (3) ensure proper operation of natural draft stacks, (4) eliminate cold drafts on workers, and (5) eliminate excessive differential pressure on doors and adjoining spaces. The method of distributing replacement air and the quantity of replacement air are critical with respect to exhaust air. Design the replacement air system in accordance with the decision tree shown in Figure 1-2.



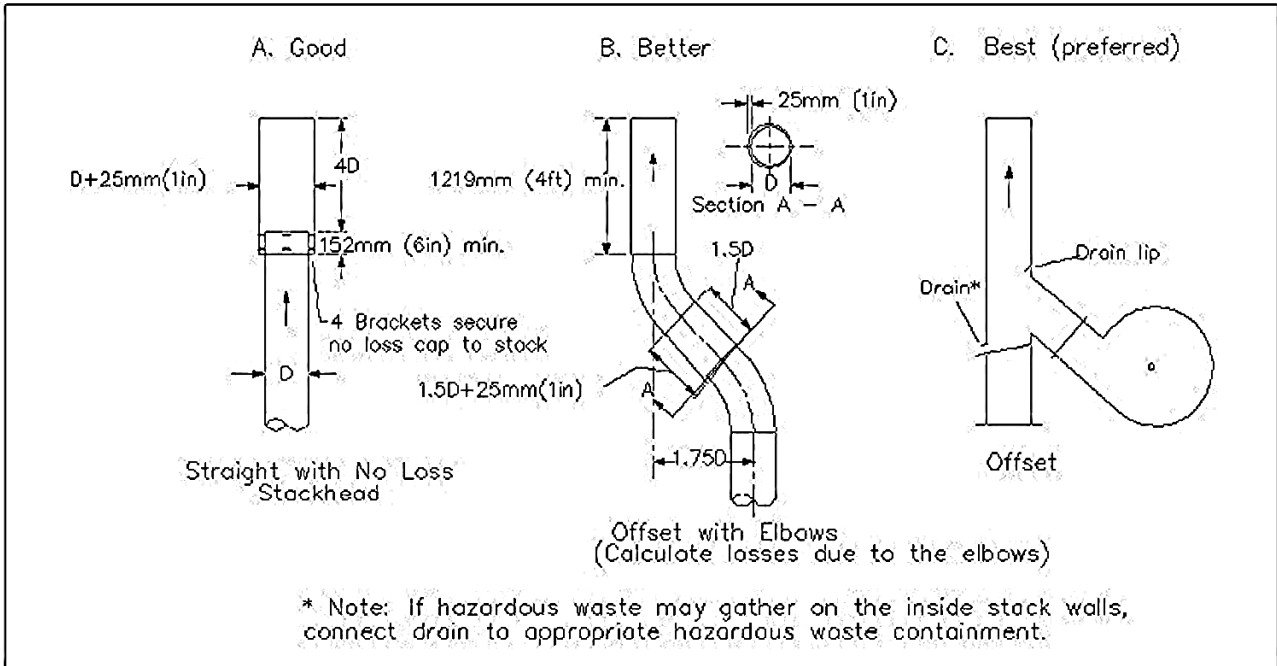

Exhaust Stack Designs

Figure 1-1

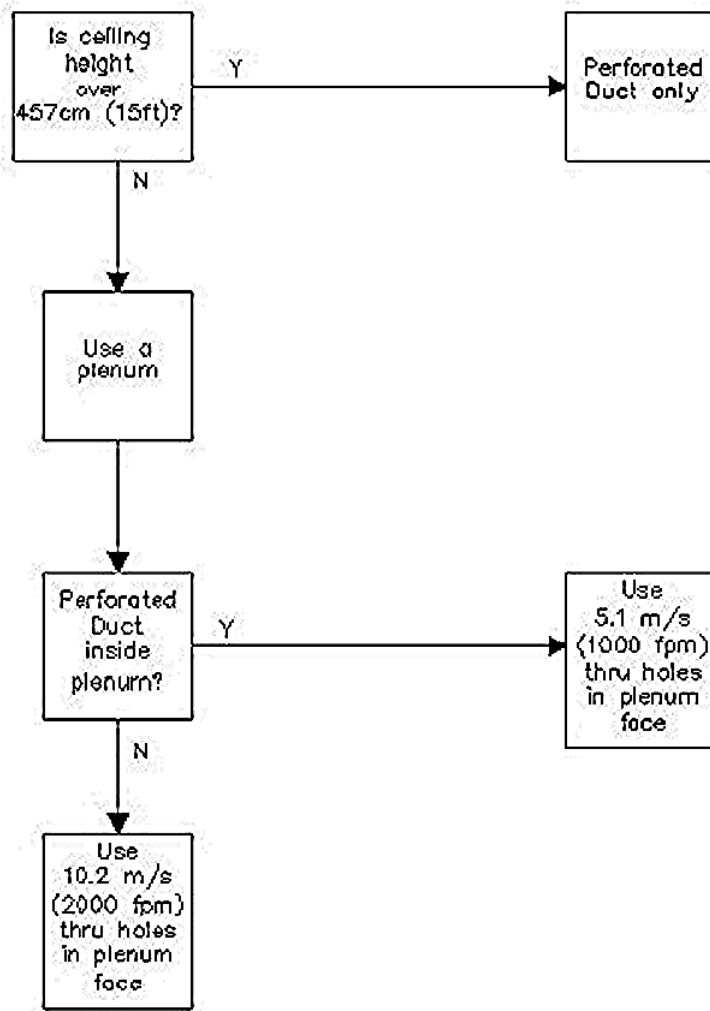

Decision Tree for Replacement Air Design

Figure 1-2

**1.3.3.1 Space Pressure Modulation.** Control the ventilated space pressure by modulating the quantity of replacement air. Use a variable frequency drive (VFD) motor to control the fan speed. Using barometric dampers to control replacement air quantity is inefficient and unreliable. Sensor controlled transfer grilles are acceptable provided there will not be a problem with contaminated migration.

**1.3.3.2 Plenum Design.** Use perforated plate to cover as much of the ceiling (or wall opposite the exhaust hood(s)) as practical. The diameter of the perforation should be between 1/4 in and 3/8 in. Perforated plenums work best when ceiling height is less

than 15 ft. Use either of the following two choices for replacement air plenum design:

- Design for 1,000 fpm replacement air velocity through the open area of the perforated plate if perforated duct is used inside the plenum as shown in Figure 1-3.

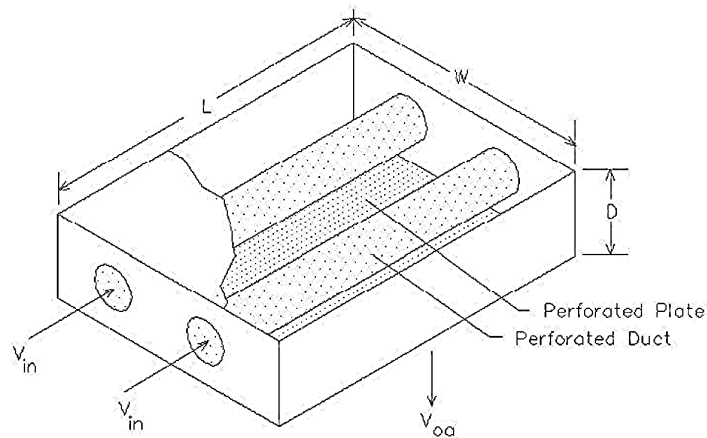

Note: Velocity through the open area of the perforated plate shall be 5.1 m/s (1000 fpm)

### Plenum Design with Perforated Duct

Figure 1-3

- Design for 2,000 fpm replacement air velocity through the open area of the perforated plate if the plenum is served with ducts using diffusers, grills or registers as shown in Figure 1-4.

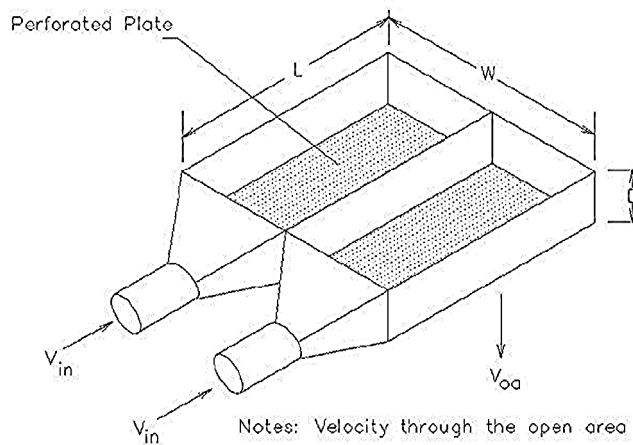

Notes: Velocity through the open area of the perforated plate shall be 10.2 m/s (2000 fpm)

### Plenum Design without Perforated Duct

Figure 1-4

**1.3.3.3 Perforated Duct Design.** Use perforated duct to evenly distribute the flow of replacement air inside a plenum or use alone when ceiling height is greater than 15 ft. Manufacturers provide several different types and sizes of perforated duct. Use recommendations from the manufacturer for duct design. The manufacturer will not only recommend the size, shape, and type of the required perforated duct, but also the location of the orifices and reducers to distribute the air properly.

**1.4 CONTROLS.** Provide industrial ventilation system controls and associated alarms to ensure contaminant control, space specific balance and conditioning, a safe and healthy work environment, and system malfunction notification.

**1.4.1 Gauges and Sensors.** Specify gauges and sensors to provide continuous monitoring of system performance. The minimum requirements are:

**1.4.1.1** Differential pressure sensors, with gauge readouts, across each replacement air filter section. Set points on the gauge to trigger an alarm when the pressure drops or gains across the filter exceed the manufacturer's recommended value. A pressure drop occurs when there is a blow through a filter and a pressure gain occurs when the filter gets loaded.

**1.4.1.2** Operating light on replacement air system fan motor.

**1.4.1.3** Static pressure sensor at the outlet of the replacement air fan with a gauge readout. Set the points on the gauge to trigger an alarm when the pressure is lower than the recommended range (as determined by baseline testing).

**1.4.1.4** Hood static pressure sensor, for critical processes or process where extremely toxic substances are used, with a gauge mounted in a conspicuous place near the hood. Set the points on the gauge to trigger an alarm when the static pressure is lower or higher than the recommended range (as determined by baseline testing). Do not use the type of inline flow sensor, which measures the pressure drop across an orifice plate. Use only a static pressure tap and differential pressure gauge.

**1.4.1.5** Differential pressure sensor across each exhaust air-cleaning device with gauge readout. Set points on the gauge to trigger an alarm when the pressure drop across the device exceeds the manufacturer's recommended value.

**1.4.1.6** Static pressure sensor at the exhaust fan inlet with gauge readout. Set the points on the gauge to trigger an alarm when the pressure is lower than the recommended range (as determined by baseline testing).

**1.4.1.7** Operating light on exhaust air system motor. When a sensor indicates a malfunction, trigger an alarm that is both audible and visible in the shop space.

**1.4.1.8** Operating ranges on all gauges clearly marked. Locate gauges on an annunciator panel (except hood static pressure gauges). Provide a 3-way valve at each gauge connection for cleanout and calibration; see Figure 1-5.

**1.4.1.9** Place room differential pressure sensors away from doors, windows, and replacement air discharge.

**1.4.2 Interlocks.** Provide an interlocked on-off switch so that the replacement air and exhaust air systems operate simultaneously. When there are multiple fans, clearly label which exhaust fan is interlocked with which supply fan.

**1.4.3 Annunciator Panel.** Provide an annunciator panel to continuously monitor ventilation system performance. Locate the panel so it is accessible to shop personnel. The panel must include, but is not limited to, all gauges (except hood static pressure gauges) described in paragraph 1.4.1. Mount fan motor operating lights and interlocked ON/OFF switch on the panel. The interlocked switches must clearly show which exhaust and supply fans are interlocked, where multiple fans are used. The panel should indicate what action to take when operation falls outside the prescribed ranges. For example, “examine/replace filter on R.A. unit when this gauge reads outside indicated range.”

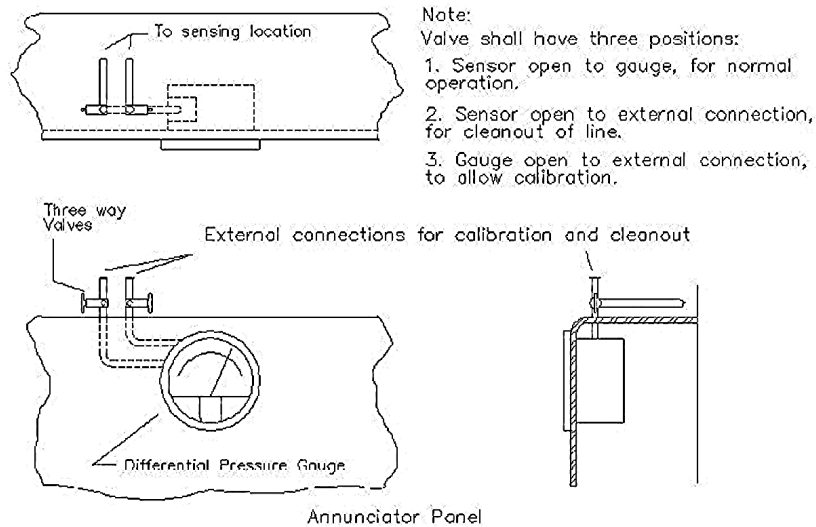

Figure 1-5

## 1.5 OPERATIONAL CONSIDERATIONS

**1.5.1 Provision for System Testing.** Provide access to the fan and motor to measure voltage, amperage, and fan speed. Specify that all testing will be done in accordance with the ACGIH IV Manual, Chapter 9, "Monitoring and Testing of Ventilation Systems."

**1.5.2 Energy Conservation.** Incorporate applicable energy conservation measures in the design of all industrial ventilation systems. Criteria herein minimize volume flow rates through appropriate designs. Evaluate life cycle costs for heat recovery systems and specify when appropriate. Refer to ASHRAE Handbook, HVAC Systems and Equipment and MIL-HDBK-1003/3 for details.

**1.5.2 Recirculation.** Industrial ventilation systems use a large quantity of air. Exhaust air recirculation is discouraged for most industrial processes and prohibited for processes generating lead and asbestos. Follow the re-circulated air guidelines set forth in NFPA 654, Standard for the Prevention of Fire and Dust Explosions from the Manufacturing, Processing, and Handling of Combustible Particulate Solids for fire protection; the ACGIH IV Manual and ANSI Z9.7, Recirculation of Air from Industrial

Process Exhaust Systems for health protection, and the applicable OSHA standards when recirculation is included in the design.

**1.5.3 Maintenance.** Require the contractor provide an operation and maintenance manual for the system and also provide hands-on training for maintenance and shop personnel.

**1.5.4 Posting.** For those systems where the replacement air is critical to the proper operation of the system, consider posting a warning sign at each entrance to the ventilated space.

**1.5.5 Noise.** Use engineering controls as the primary means of protecting personnel from hazardous noise. It is cheaper to eliminate potential noise problems during the design or procurement stages, than it is to retrofit or modify after installation. Determine the acoustic environment of any kind of activity in advance, both to fulfill the design goals and prevent the need for corrections at a later stage.

**1.5.5.1 Criteria.** Specify the lowest noise emission level that is technologically and economically feasible. Each DOD service branch has a permissible noise level specified in its safety and health manual. It is not adequate to specify that individual pieces of equipment do not produce noise levels in excess of that permissible level. Determine the sound power levels for each piece of equipment. Use this information to predict the acoustic characteristics of the workspace and the resulting ambient noise level. Specify the appropriate noise control method if the total predicted ambient noise level is in excess of the requirements in the applicable safety and health manual. For additional information on noise control refer to *Design: Noise and Vibration Control*; DHEW 79-117, *NIOSH Industrial Noise Control Manual*; OSHA Pub 3048, *Noise Control*, and *A Guide for Workers and Employees*.

**1.5.6 Respiratory Protection.** 29 CFR 1910.134(d), Respiratory Protection specifies requirements for respiratory protection. Consult with an industrial hygienist or occupational health specialist to determine the appropriate type of respiratory protection



required for each process.

**1.5.6.1 Breathing Air.** Breathing air for supplied air respirators must meet grade D standards as required by 29 CFR 1910.134(d) and defined in Compressed Gas Association Specification for Air G-7.1. Breathing air couplings must not be compatible with outlets for non-respirable worksite air or other gas systems. Consider providing multiple connection ports for airline respirator hoses to allow worker mobility. Consider installing a panel to permit the IH to test air quality on a routine basis.

**1.5.6.2 Air Compressors.** Oil lubricated breathing air compressors require a high temperature or carbon monoxide alarm or both. If only a high temperature alarm is used, the air supply must be monitored to ensure the breathing air does not exceed 10 parts per million (ppm) carbon monoxide. Compressors that are not oil lubricated must still have the carbon monoxide level monitored to ensure it is below 10 ppm.

Compressors used to supply breathing air must be constructed and situated to prevent entry of contaminated air into the air supply system. The breathing air compressor must minimize moisture content so that the dew point is 5.56 °C (10 °F) below the ambient temperature. The breathing air system must have suitable inline air-purifying sorbent beds and filters. Sorbent beds and filter will have to be maintained per manufacturer's instructions.

**1.5.7 Emergency Showers and Eyewash Stations.** Provide where required.

**1.5.8 Hygiene Facilities.** These facilities are adjacent to or nearby the operation when employees are exposed to certain stressors such as asbestos, cadmium, lead, etc. The facilities may be as simple as a hand washing station or as complicated as multiple clean/dirty rooms in an asbestos delagging facility. Consult with the local industrial hygiene department to determine the extent of and location for these facilities.

**1.6 COMMISSIONING.** This process begins before the conceptual design is complete. It is a strategy that documents the occupants' needs, verifies progress and contract compliance and continues throughout the design, build and acceptance process. To ensure that issues specific to ventilation are not overlooked, consider using *ASHRAE*

*Guideline 1, The HVAC Commissioning Process.*

## **2. WOOD SHOP FACILITIES**

**2.1 FUNCTION.** Use the design criteria discussed here as a general guideline for developing ventilation systems for wood shops.

**2.2 OPERATIONAL CONSIDERATIONS.** A properly designed ventilation system will control the dust level within the shop. Exposure to wood dust may lead to health problems. The accumulation of wood dust can create explosion and fire hazards. Even if a ventilation system is installed to collect most of the dust, manual cleaning at each machine and throughout the shop is still necessary. Restrict woodworking exhaust systems to handling only wood dust. Do not connect any other process that which could generate sparks, flames, or hot material to a woodworking exhaust system.

**2.3 FLOOR PLAN LAYOUT.** Contact the shop personnel who will be working with the machinery to get their input on workflow and specific equipment. Design the ventilation system to complement equipment layout and minimize housekeeping.

**2.4 DESIGN CRITERIA.** Design the facility using general technical requirements in *NFPA 664, Prevention of Fires and Explosions in Wood Processing and Woodworking Facilities* and the specific requirements discussed here.

**2.4.1 Exhaust Air System.** Calculate the system capacity on the basis that the system operates with all hoods and other openings, such as floor sweeps, open. Refer to the ACGIH IV Manual, Chapter 10, for determining the exhaust flow rate for specific wood shop machines.

**2.4.1.1 System Layout.** Lay out the system to meet the shop requirements. Consider locating machines with the greatest hood resistance as close as possible to the fan. In most cases, ductwork is located along the ceiling and walls; however, running ductwork under removable grates or panels in the floor may reduce duct lengths and leave more working space around machinery. Refer to NFPA 650, *Pneumatic Conveying Systems for Handling Combustible Particulate Solids* and 664 for information on wall penetrations

and clearances.

**2.4.1.2 Plenum Exhaust System.** An alternative to the tapered system is a plenum system, described in the ACGIH Manual, Chapter 5. A plenum system allows equipment to be move equipment in the shop and may be more efficient. Ducts can be added or removed, as equipment needs change. See the ACGIH IV Manual Chapter 5 for further considerations.

**2.4.2 Hood Design.** Provide a hood for each operation that produces dust. This includes sawing, shaping, planing, and sanding operations. Design and position all hoods so the wood dust will fall, be projected, or be drawn into the hood in the direction of the airflow. Construct hoods of noncombustible materials. Ensure the hoods do not interfere with worker operations. In some cases, the exhaust hood may be utilized as a safety guard. Refer to the ACGIH IV Manual, Chapter 10 for woodworking hood designs. Modify the drawings as necessary to meet the specific equipment and process requirements.

**2.4.3 Floor Sweeps.** If the design includes floor sweeps, include a means, such as magnetic separators, to prevent scrap metal from entering the system. Figure 2-1 shows a basic floor sweep design. The floor sweep is only opened during shop clean up. If the system design calculations indicate that, when opened, the floor sweep provides a transport velocity of less than 17.78 m/s (3,500 fpm,) design the system to include floor sweeps in the normally opened position without a hinged cover.

**2.4.4 Ductwork.** See above for general ductwork design. See NFPA 664 for specific requirements on wood shop ductwork construction. Size the ductwork to maintain a minimum transport velocity as specified in the ACGIH IV Manual, Chapter 10, Woodworking. Use only metal ductwork and conductive flexible hose. Bond and ground all ductwork in accordance with NFPA 664. The ductwork must be designed on the basis that all hoods and other openings connected to the system are open.

**2.4.5 Blast Gates.** Provide blast gates only for the specific purpose of balancing the

airflow. Do not use blast gates to isolate equipment from the exhaust system with the intent to reduce the overall airflow requirement. When possible, install blast gates on horizontal

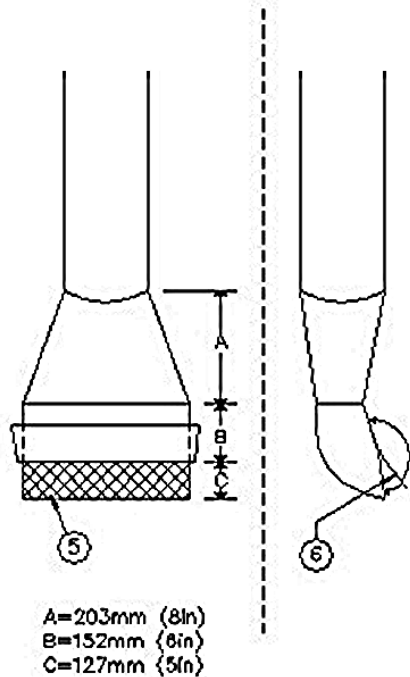

WHEN DESIGNING OR PURCHASING A FLOOR SWEEP, KEEP THESE POINTS IN MIND:

1. SIZE THE DUCT FOR A MINIMUM TRANSPORT VELOCITY (MTV) OF 17.8 M/S (3500 FPM).
2. USE A FLOW RATE OF 0.4 TO 0.7 M<sup>3</sup>/S (800 TO 1400 CFM) AND INCLUDE THESE IN SHOP DESIGN CALCULATIONS.
3. ACHIEVE A VELOCITY OF 10.2 M/S (2000 FPM) AT THE FLOOR SWEEP INLET.
4. EXTEND THE FLOOR SWEEP TO THE FLOOR.
5. COVER THE SWEEP OPENING USING WIRE MESH WITH 12 MM (1/2 IN) ROUND OR SQUARE HOLES.
6. USE A HINGED COVER TO BE CLOSED WHEN SWEEP IS NOT BEING USED.
7. DIMENSIONS ARE APPROXIMATIONS AND CAN VARY IF POINTS 1 THROUGH 6 ARE MET.
8. CONSIDER USING A MAGNET INSIDE THE SWEEP TO TRAP METAL SCRAP. REFER TO NFPA 654.

### Floor Sweep

Figure 2-1

runs and orient the gate so the blade is on the top half of the duct and opens by pulling the blade towards the ceiling. When possible, blast gates must be installed at a location not easily accessible to shop personnel. After final balancing and acceptance, secure the blade and mark its position so that it can be returned to the balanced position if inadvertently moved. When the blast gate cannot be placed out of the reach of shop personnel, then lock the blade in position. For example, drill a hole through the body and blade of the gate and then insert a bolt and tack weld it.

**2.4.6 Duct Support.** If sprinkler protection is provided in the duct, horizontal ductwork must be capable of supporting the weight of the system, plus the weight of the duct half-

filled with water or material being conveyed, whichever has the higher density.

**2.4.7 Air Cleaning Devices.** Locate the air-cleaning device outside the building.

## **2.5 SAFETY AND HEALTH CONSIDERATIONS.**

- Refer to section 7.2.2 of ANSI O1.1, Woodworking Machinery, Safety Requirements for personal protective equipment.
- Provide a means for separately collecting and disposing of any metal scrap such as nails, band iron, or any wood containing metal. Do not use the woodshop ventilation system to pick up these materials.
- Avoid the use of wood painted with paints containing lead, hexavalent chromium, cadmium, or coated with wood preservatives. Otherwise, consult an industrial hygienist to determine the exposure level and the level of respiratory protection needed.
- Use sharp and clean blades at the correct feed rate to generate less heat. The generated heat can raise the wood or wood-containing product to ignition temperature that could start a fire.

### 3. PAINT SPRAY BOOTHS

**3.1 FUNCTION.** Paint spray booths provide surface finishing capabilities for a wide range of parts, equipment, and vehicles. Paint spray booth sizes range from bench type units for painting small parts, to large walk-in booths or rooms for painting vehicles, tractors or large equipment.

**3.2 OPERATIONAL CONSIDERATIONS.** During paint spray operations, paint is atomized by a spray gun and then deposited on the object being painted. Depending on the application equipment and spray method used, transfer efficiencies vary greatly. Transfer efficiency is the amount of paint solids deposited on a surface divided by the total amount of paint sprayed, expressed as a percentage. a. Use equipment with a high transfer efficiency, such as electrostatic or high volume low pressure (HVLP) spray guns, to reduce overspray. Overspray is the paint that is sprayed but not deposited on the surface being painted. This equipment not only saves in paint cost, but also reduces volatile organic compound (VOC) emissions and maintenance requirements. b. Warm the paint before applying, whenever possible. This lowers the paint viscosity enabling spray painting at a lower pressure, thereby minimizing the amount of overspray generated. The lower viscosity also decreases the quantity of solvent used to thin the paint prior to spraying. This results in reduced solvent consumption and VOC emissions.

**3.2.1 Painting Equipment Types.** Spray-painting equipment must conform to national, state, and local emission control requirements. One of these requirements is transfer efficiency. Five primary types of paint spraying equipment and their typical transfer efficiencies include:

- Conventional air spray (25 percent transfer efficiency).
- Airless spray (35 percent transfer efficiency).
- Air-assisted airless spray (45 percent transfer efficiency).
- Electrostatic spray (65 percent transfer efficiency).

- High volume/low pressure (HVLP) spray (up to 75 percent transfer efficiency).

**3.3 DESIGN CRITERIA.** Design or procure paint spray booths in accordance with the general and specific requirements discussed here.

**3.3.1 Walk-in Spray Paint Booths.** The ventilation system for a walk-in booth is mainly to prevent fire and explosion. A well-designed ventilation system will also reduce paint overspray, help control workers' exposure, and protect the paint finish. Workers must use appropriate respiratory protection irrespective of the airflow rate. On 9 February 2000, OSHA issued an interpretation of 29 CFR 1910.94 and 1910.107, Spray Finishing Using Flammable and Combustible Materials for determining the airflow rate required for a walk-in paint booth. In accordance with OSHA's interpretation letter, following NFPA 33 will provide protection from fire and explosion. The guidance listed in Subpart Z of 29 CFR 1910.94 provides protection for workers. See Appendix B for OSHA's interpretation. a. Use the Painting Operations section in the ACGIH IV manual to determine the design volumetric airflow rate. Ensure that this design volumetric airflow rate will keep the concentration of vapors and mists in the exhaust stream of the ventilation system below the 25 percent of the LEL. See 1910.94(c)(6)(ii) for an example of airflow rate requirement calculations. b. Do not re-circulate exhaust air while painting.

**3.3.1.1 Exhaust Configurations.** The two main ventilation system configurations are downdraft and crossdraft. In a downdraft booth, air enters through filters in the ceiling of the booth and leaves through filters that cover trenches under a metal grate floor. In a crossdraft booth, air enters through filters in the front of the booth and leaves through filters in the back of the booth. Both configurations are commercially available.

**3.3.1.1.1 Downdraft Paint Spray Booths.** Downdraft booth configuration provides a cleaner paint job than the crossdraft booth configuration and controls exposures to workers better than crossdraft booth configuration. The downdraft configuration should be the primary choice in designing or selecting of paint spray booths. Figure 3-1 is an example of a downdraft configuration.

**3.3.1.1.2 Crossdraft Paint Spray Booths.** The crossdraft paint spray booth usually requires less total volumetric airflow rate than the downdraft spray paint booth because



the vertical cross-sectional area of the booth is often smaller than the booth footprint area. Figures 3-2 and 3-3 are examples of drive-through crossdraft paint spray booth configurations.

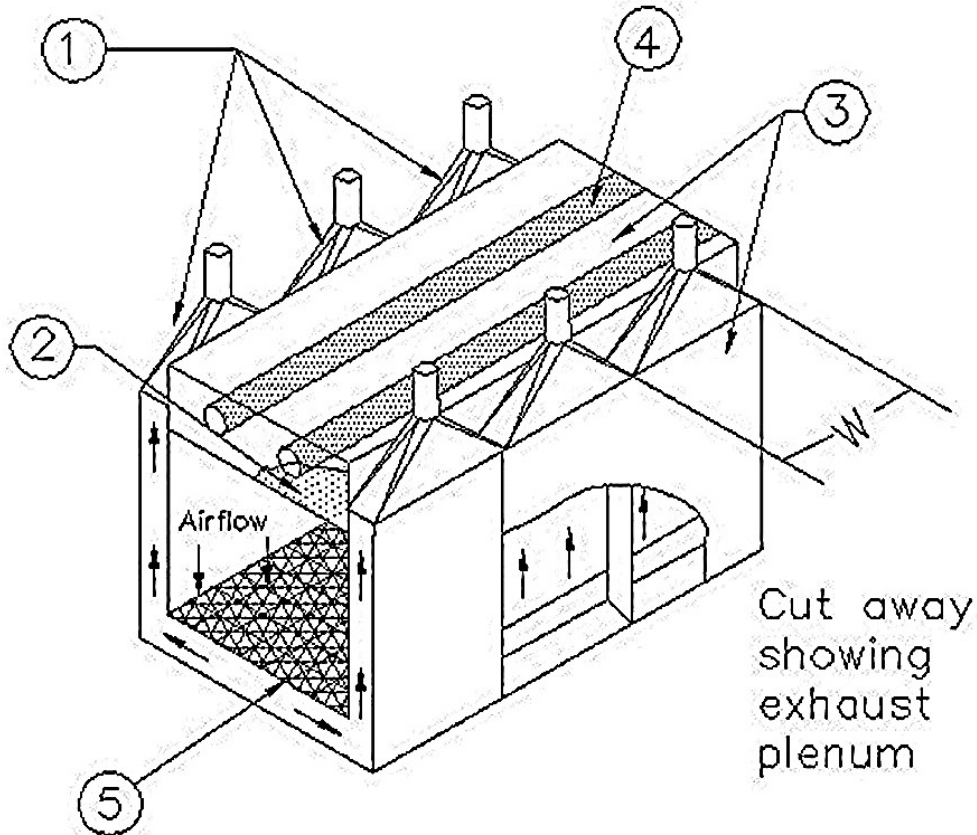

Drawing shown with roll-up doors removed

NOTES:

1. Size each plenum take-off for no more than 8 ft of plenum width (W).
2. Perforated plate with 3/8-in holes. Size open area for an airflow velocity of 1,000 fpm through holes.
3. Size exhaust plenum for a maximum plenum velocity of 1,000 fpm. Size replacement air plenum for a maximum plenum velocity of 500 fpm.
4. Use manufacturer's recommendations for sizing perforated ductwork.
5. Removable filters and floor grating.

**Walk-in downdraft paint booth.**

Figure 3-1

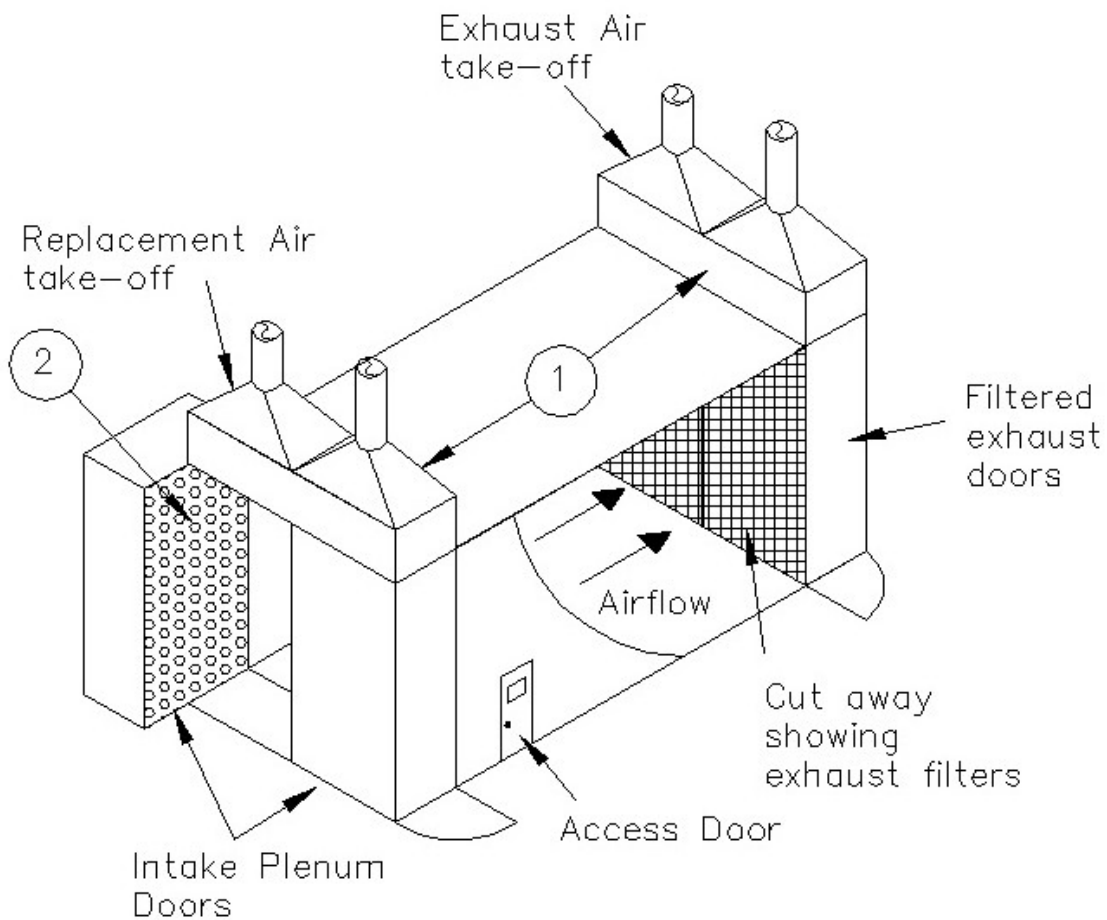

**NOTES:**

1. Size each plenum take-off for no more than 8 ft of plenum width. Size the exhaust plenum for a maximum plenum velocity of 1,000 fpm. Size replacement air plenum for a maximum plenum velocity of 500 fpm.
2. Perforated plate with 3/8-in holes. Size open area for an airflow velocity of 2,000 fpm through holes.

**Drive-through cross draft paint booth with mechanical replacement air.**

Figure 3-2

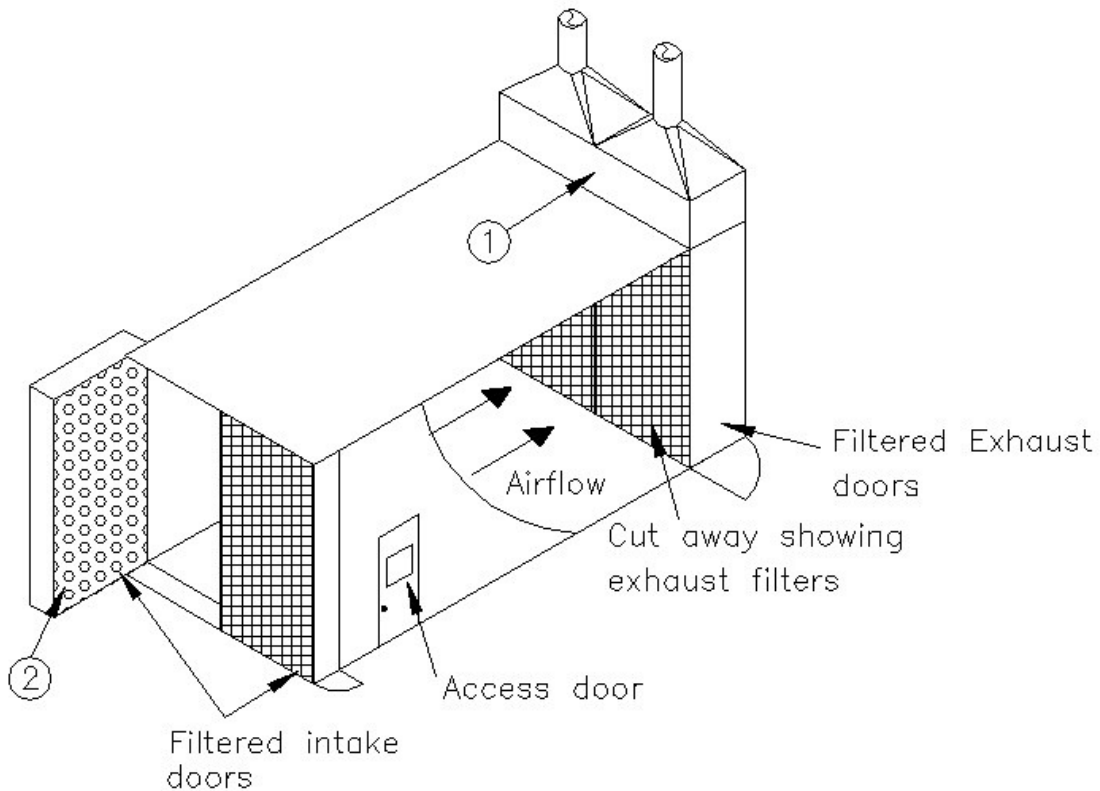

**NOTES:**

1. Size each plenum take-off for no more than 8 ft of plenum width. Size the exhaust plenum for a maximum plenum velocity of 1,000 fpm. Size replacement air plenum for a maximum plenum velocity of 500 fpm.
2. Perforated plate with 3/8-in holes. Size open area for an airflow velocity of 2,000 fpm through holes.

**Drive-through crossdraft paint booth with no Mechanical replacement air**

Figure 3-3

**3.3.1.2 Paint Spray Booth Exhaust Filtration System.** There are two types of exhaust air filtration systems. The first type is a water wash system. A water curtain is created at the exhaust plenum by a pump providing continuous circulation of water. The second type is a dry filter system, where the exhaust air passes through filter media. Consider the following:

- Do not design or purchase the water wash paint spray booths. The water wash system requires more energy to operate than the dry filter system. The wastewater must be treated and the hazardous constituents removed (often at great cost to the generating facility) before it may be discharged to a municipal treatment plant.
- Neither water wash nor dry filter filtration systems can reduce the concentration of volatile organic compounds in the exhaust air stream. Consult the environmental department for controlling volatile organic compounds.

**3.3.2 Storage and Mixing Room.** Refer to the ACGIH IV Manual, Paint Mix Storage Room, VS-75-30 for the design of ventilation system.

**3.3.3 Paint Mix Hoods.** Figure 3-4 is an example of a workbench and a floor hood designed for paint mixing. Provide 100 cfm per square foot of hood face.

**3.4 FANS AND MOTORS.** Use explosion proof motor and electrical fixtures for exhaust fan. Do not place electric motors, which drive exhaust fans, inside booths or ducts.

**3.5 REPLACEMENT AIR.** There is no control over the room temperature or room static pressure for non-mechanical replacement air systems. Dust from outside often enters the paint spray booths through cracks and damages the paint finish. Therefore, provide a mechanical replacement air system to maintain a neutral air pressure inside the booth. This will prevent dust from entering the paint spray area. The neutral air pressure will also prevent paint overspray and vapors from escaping the booth and

migrating into adjacent work areas. For paint mixing room replacement air, refer to the ACGIH IV Manual, Paint Mix Storage Room, VS-75-30.

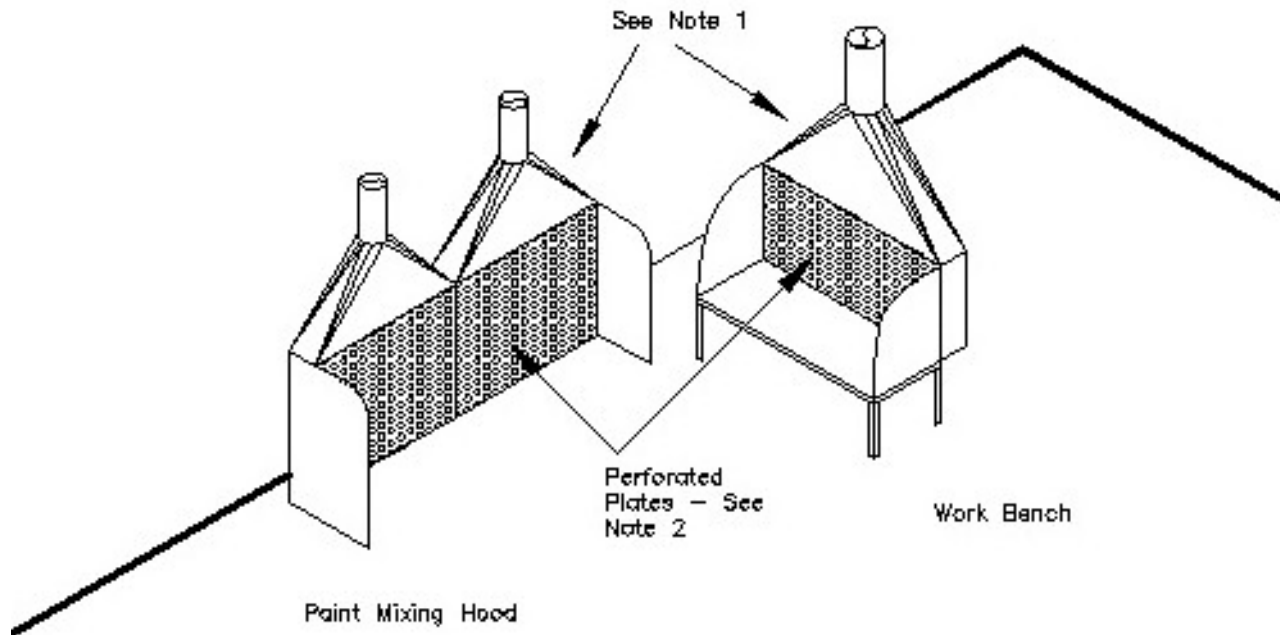

NOTES:

1. Size each plenum take-off for no more than 8 ft of plenum width. Size each plenum for a maximum plenum velocity of 1,000 fpm.
2. Perforated plate with 3/8-in holes. Size open area for an airflow velocity of 2,000 fpm through holes.

Paint Mixing Hood and Work Bench

Figure 3-4

**3.5.1 Air Distribution.** Distribution of replacement air within the spray booth is as significant as the average air velocity through the booth. Distribute the replacement air evenly over the entire cross section of the booth to prevent turbulence or undesirable air circulation. The preferred means of distributing the replacement air is through perforated plate as shown in Figures 3-1, 3-2, and 3-3.

**3.5.2 Heating and Air Conditioning.** Most new paint spray booth ventilation systems have a painting mode and a curing mode. Do not re-circulate air during the painting mode. About 10 percent of the booth airflow is from outside the booth and 90 percent of the exhaust air is recycled during curing. Review the paint drying requirements before specifying temperature and humidity ranges. Refer to ANSI Z9.7 for exhaust air re-circulation requirements.

**3.6 SYSTEM CONTROLS.** Design system controls in accordance with paragraph 1.4.

**3.7 RESPIRATORY PROTECTION.** See paragraph 1.5.6.

# QUIZ

## AN INTRODUCTION TO DESIGN OF INDUSTRIAL VENTILATION SYSTEMS

1. There are \_\_\_\_\_ steps in the general design procedure for industrial ventilation systems:
  - a. 6
  - b. 7
  - c. 8
  - d. 9
  
2. Exhaust systems for paint mix hoods should be sized for \_\_\_\_\_ cubic feet per minute per square foot hood face:
  - a. 50
  - b. 100
  - c. 150
  - d. 200
  
3. \_\_\_\_\_ is as important as exhaust air in controlling industrial process contaminants:
  - a. discharge temperature
  - b. particulate density
  - c. replacement air
  - d. residual pollution
  
4. The two types of paint spray booth exhaust filtration systems are a water wash system and a \_\_\_\_\_:
  - a. recirculating system
  - b. dry filter system
  - c. heat pump
  - d. liquid separation tank

5. Pressure in the ventilated space is usually modulated by controlling the \_\_\_\_\_:

- a. replacement air
- b. exhaust stack back-pressure
- c. leakage in exhaust ducts
- d. annunciator panel

6. The total area of perforation holes in the replacement air plenum of a drive-through crossdraft paint booth with no mechanical replacement air should be sized for a minimum velocity of \_\_\_\_\_ feet per minute through the holes:

- a. 1000
- b. 1200
- c. 1500
- d. 2000

7. The exhaust air and replacement air fans should have \_\_\_\_\_:

- a. interlocked on-off switches
- b. constant impeller rotation rate
- c. sound power levels (SPL) above 120 dB
- d. integral respiratory filters

8. The exhaust plenum for a drive-through cross draft paint booth should be sized a maximum plenum velocity of \_\_\_\_\_ feet per minute:

- a. 1000
- b. 1200
- c. 1500
- d. 2000

9. Breathing air for respirators is usually supplied by \_\_\_\_\_:

- a. partial diversion from exhaust air ducts
- b. recirculated replacement air
- c. the exhaust air fan
- d. a separate compressor



10. The total area of perforation holes in the replacement air plenum of a walk-in downdraft paint booth should be sized for a minimum velocity of \_\_\_\_\_ feet per minute through the holes:

- a. 400
- b. 600
- c. 800
- d. 1000

11. Transport velocity for floor sweep ducts in wood shops should be at least \_\_\_\_\_ feet per minute:

- a. 2500
- b. 3000
- c. 3500
- d. 4000

12. Each plenum take-off for a walk-in downdraft paint booth should be sized for no more than \_\_\_\_\_ feet of plenum width:

- a. 4
- b. 6
- c. 8
- d. 10

13. The purpose of blast gates on ductwork in wood shops is to:

- a. eliminate need for static pressure gauges
- b. reduce risk of explosion caused by sparks
- c. conserve energy
- d. balance the system

14. Each floor sweep in a wood shop should be designed for at least \_\_\_\_\_ CFM:

- a. 700
- b. 800
- c. 900
- d. 1000

15. Consideration should be given to installing a \_\_\_\_\_ inside a wood shop floor sweep to trap metal scrap:

- a. magnet
- b. electrostatic precipitator
- c. screen with 1/4-inch minimum mesh
- d. cyclone separator