

# Earth Fault Protection



---

# Earth Fault Protection

By

Velimir Lackovic, Electrical Engineer

PDHLibrary Course No 2025007  
2 PDH HOURS

---

Fault statistic suggests that earth faults are dominating fault type. Therefore, earth fault protection is of great importance in electrical networks. The type of the used earth fault protection depends primarily on the type of the earthing method. This course describes protection principles for solidly-(effectively), reactance, high resistance and resonance grounded electrical systems.

### **Solidly Grounded Systems**

In the solidly earthed systems all transformers are connected to ground. Therefore, they feed earth fault current to the fault. The overall contribution from all earthing locations sets special requirements for the protection arrangement.

### **Fault Levels and Fault Resistance**

In order to obtain fault levels in solidly grounded electrical system, symmetrical components are usually used. Single line diagram of a 132kV electrical system is shown in Figure 1 while its representation using symmetrical components is provided in the Figure 2.

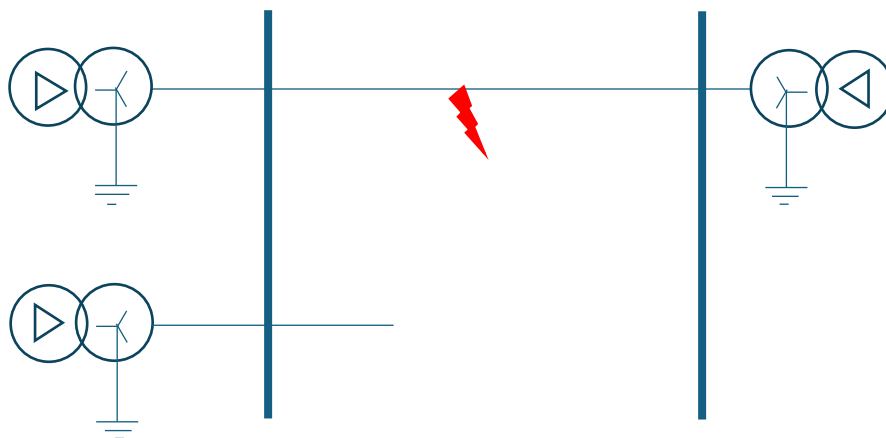

Figure 1. Ground fault in a direct, solidly grounded electrical system

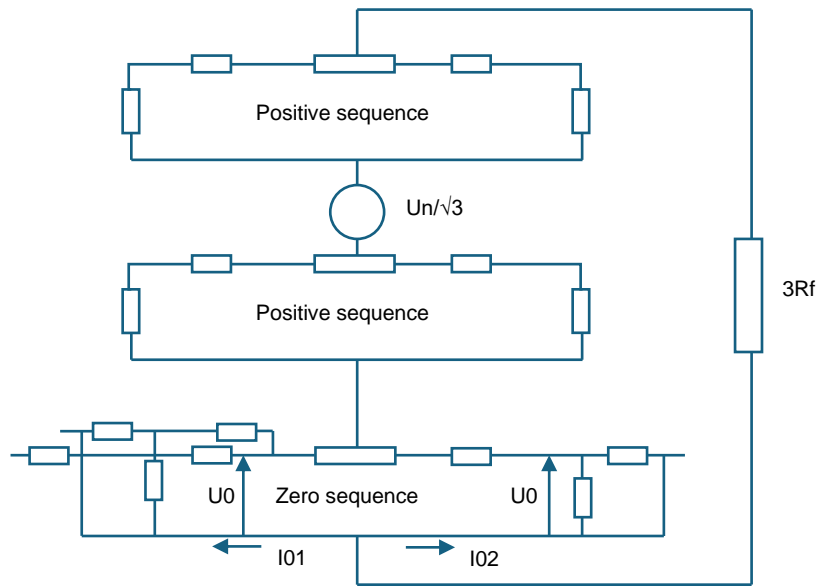

Figure 2. The symmetrical components are used to find the “I0” current

For the line to ground fault shown in Figure 1, “3I0” is the total fault current. Fault current distribution, from the different system grounding points, can be derived from the distribution in the zero sequence network (as shown in Figure 2). By applying different fault resistances one can get the fault current level. The fault resistance “R<sub>f</sub>”, contains the arc resistance and the tower foot resistance. The arc resistance is determined using the following expression:

$$R_{arc} = \frac{28700a}{I_f^{1.4}}$$

where “a”, is the arc length in meter, typically the insulator length, and “I<sub>f</sub>” is the fault current. A calculation shows that obtained values range from below 1 Ω for heavy faults, up to 50-400 Ω for high resistive ground faults. The tower foot resistance is dependent on the grounding effectiveness of the towers, whether top lines are used etc.

## Neutral Point Voltages

The neutral point voltage, at different positions is shown in Figure 2. The designate “ $U_0$ ”, represents the neutral point voltage ( $3U_0=U_N$ ). It has to be noted that “ $U_0$ ” is generated by the ground fault current “ $I_0$ ” through the zero sequence source. This means that the angle between “ $U_0$ ” and “ $I_0$ ” is always same as the zero sequence source angle. This angle does not depend on the fault resistance and the angle between the faulty phase voltage and the line current in the faulty phase. It has to be clear that that “ $U_N$ ” will be very low when sensitive ground fault relays are installed in a strong network with low zero sequence source impedances.

For example, we can observe the 132kV network shown in Figure 1 and Figure 2. With an “ $I_N$ ” setting of 120A, the “ $I_0$ ” is 40A and with a zero sequence source impedance of say 20  $\Omega$ , the zero sequence voltage component “ $U_0$ ” will be  $40 \times 10 = 400V$  and “ $3U_0$ ” will then be 1200V. This will, with an open delta winding with 110V secondary, mean a percentage voltage of 1.6%, i.e. the polarizing sensitivity of directional ground fault relays must be high. In an open delta secondary circuit there is a voltage also during normal running condition due to unbalances in the network. The voltage is mainly of third harmonic, roughly around 0,2-0,5% with conventional VTs and 1-3% together with CVTs. This means that the sensitive directional ground fault protection must be provided with a third harmonic filter when used together with CVTs. The filtering needs to be quite heavy to ensure correct directional measuring for 1% fundamental content also with third harmonic contents of approximately 3%.

## Restricted Earth Fault Protection (REF)

For solidly grounded systems a restricted earth fault protection is typically provided as an addition to the normal transformer differential relay. One of the major advantages of the restricted earth fault relays is their high sensitivity. Sensitivities of 2-8% can be accomplished. The level depends on the current transformers magnetizing currents while the normal differential relay will have sensitivities of 20-40%.

Restricted earth fault relays are also very fast due to the simple measuring technique and the measurement of only one winding. The differential relay demands percentage through fault and second harmonic inrush stabilization which always will limit the minimum operating time.

The connection arrangement of a restricted earth fault relay is presented in Figure 3. It is connected across each transformer winding.

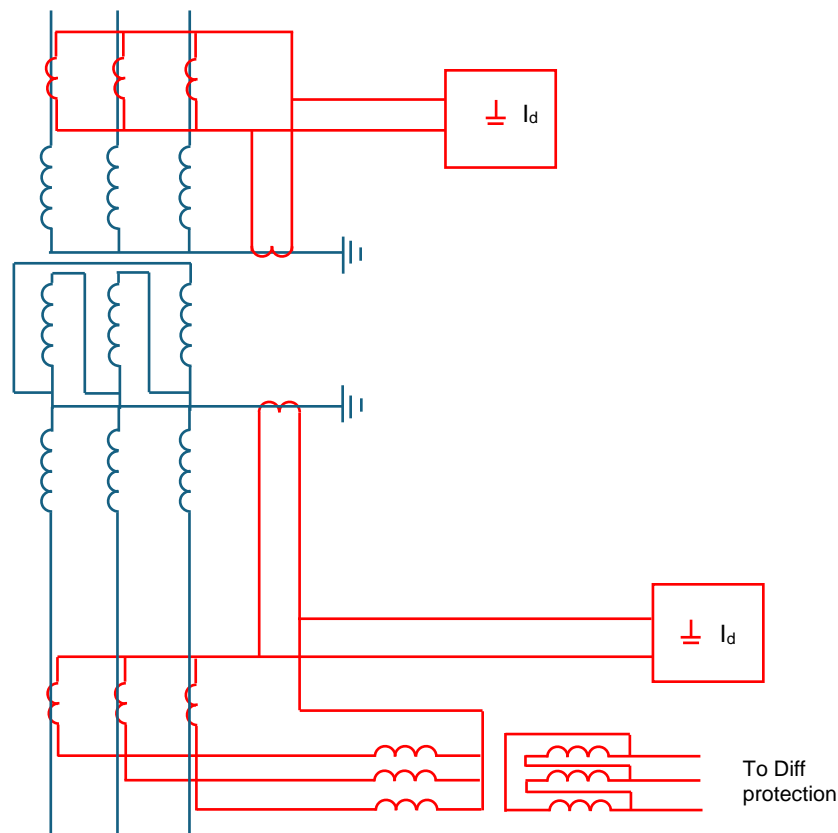

Figure 3. A Restricted Earth Fault (REF) relay for an YNdyn transformer

It is typical practice to connect the restricted earth fault relay in the same current circuit as the transformer differential relay. Due to the differences in the measuring principle, this will limit the differential relay possibility to sense ground faults. Such faults are discovered by the REF. The mixed connection in the transformer low voltage winding is shown in the Figure 3.

The typical operating method for restricted earth fault relays is the high impedance principle. This is shown in Figure 4.

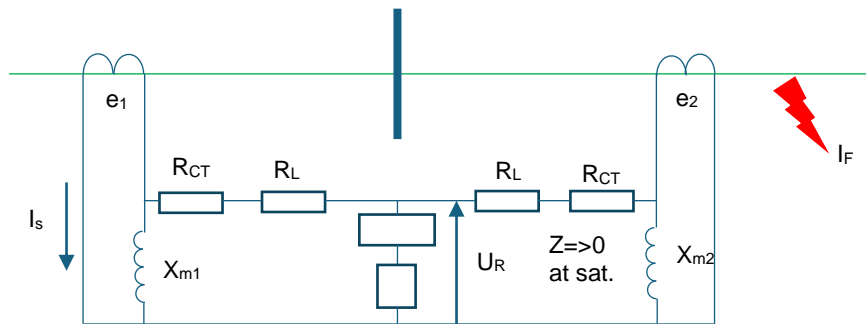

Figure 4. The high impedance principle

The relay gives high impedance to the current. The current will, for through loads and through faults, circulate in the current transformer circuits, not go through the relay. For a through fault one current transformer might saturate when the other will still feed current. In that case a voltage can be achieved across the relay. The calculations are done for the worst possible case and an operating voltage “ $U_R$ ” is determined using the following expression:

$$U_R \geq I_{Fmax}(R_{ct} + R_l)$$

where

“ $I_{Fmax}$ ” is the maximum through fault current at the secondary side, “ $R_{ct}$ ” is the current transformer secondary resistance and “ $R_l$ ” is the circuit loop resistance.

The maximum operating voltage needs to be calculated (neutral loop and phase loop need to be verified) and the relay set higher than the highest achieved value. For an internal fault the circulation is not possible and due to the high impedance the current transformers will immediately saturate and RMS voltage with the size of current transformer saturation voltage will be achieved across the relay. Due to the fast saturation very high voltages can be obtained. To prevent the risk of flashover in the circuit, a voltage limiter needs to be installed. The voltage limiter can be either in the

form of a surge arrester or voltage dependent resistor.

The relay sensitivity is determined by the total current in the circuit according to the following expression:

$$I_p \geq n(I_R + I_{res} + \sum I_{mag})$$

where “n” is the CT ratio, “I<sub>R</sub>” is the current through the relay, “I<sub>res</sub>” is the current through the voltage limiter and “ΣI<sub>mag</sub>” is the sum of the magnetizing currents from all CT’s in the circuit. It has to be noted that the vectorial sum of the currents must be used. The current measurements have to be DC insensitive to allow a use of fault current AC components in the calculations.

### **Logarithmic Inverse Relay**

Detection of ground fault and back-up tripping with maintained selectivity in a solidly grounded system is rather complicated due to the infeed of fault current from different directions. A special inverse characteristic with a logarithmic curve has been developed. It is appropriate for these applications. The principle for ground fault relays in solidly grounded system is presented in Figure 5 and the logarithmic inverse characteristic is presented in Figure 6. The inverse characteristic is chosen so that if the current of the biggest infeed is less than 80% of the faulty objects current selectivity is accomplished.

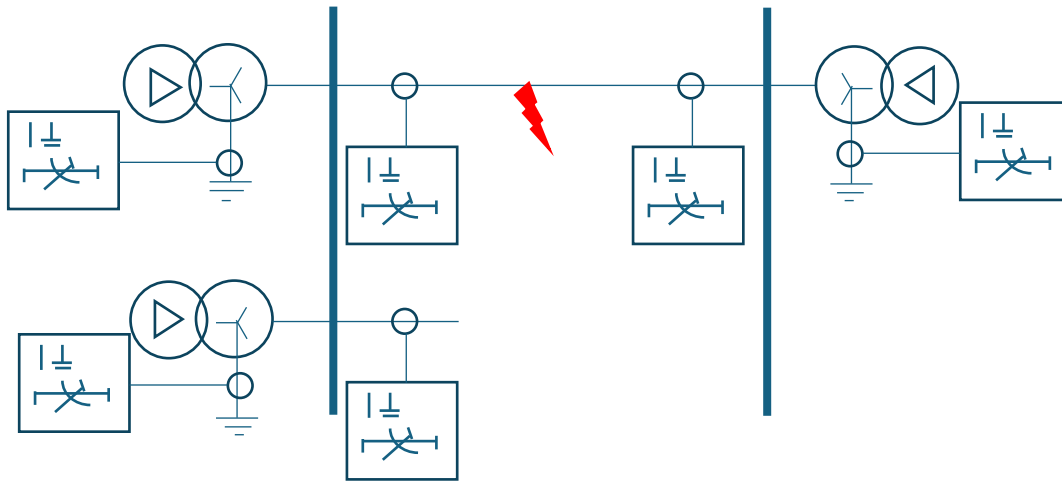

Figure 5. Ground fault protection in a solidly grounded electrical system

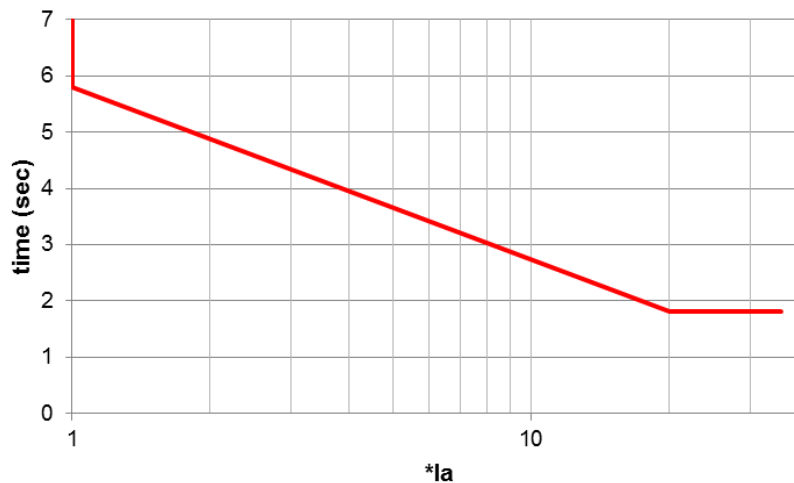

Figure 6. The logarithmic inverse characteristic, a fault current of the biggest infeed less than 0,8 times the current of the faulty object, ensures a selective tripping

To allow combined usage with distance protection, a definite minimum time is used (typically 0.3 sec.). This ensures that a single phase tripping for heavy single phase faults can be first done by distance protection relay.

## Directional Comparison Arrangements

It is a common practice to use a directional comparison arrangement with directional ground fault relays at both ends of the power line in order to detect high resistance ground faults in an solidly grounded network. The relays at the two ends are directed towards each other and a communication between the relays, through a power line carrier (PLC) or a radio link, is provided.

## Principle for Communication Arrangements

Communication is done according to two main arrangements:

- Permissive arrangement
- Blocking arrangement

In a permissive arrangement the Directional ground fault relays will send a signal to the remote end at detection of a forward fault. At signal reception and detection of a forward fault at the receiving end, an instantaneous trip is issued. Typically, the same situation happens at both ends. A permissive arrangement is presented in Figure 7.

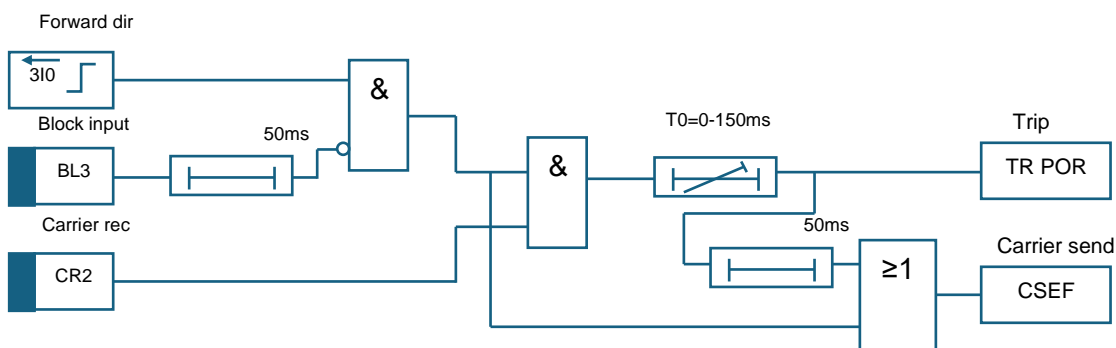

Figure 7. A permissive overreaching arrangement (POR) with directional ground fault relays

In a blocking arrangement the directional ground fault relays are equipped with a reverse locking element as an addition to the forward element. The reversed element is set to be more sensitive than the forward element and will, when a reverse fault is

sensed, send a signal to the remote end. At the remote end the forward element is equipped with a short time delay “T0” typically set to 50-150 ms, to verify if a blocking signal is received. If not, the relay will operate. The blocking arrangement principle is presented in Figure 8.

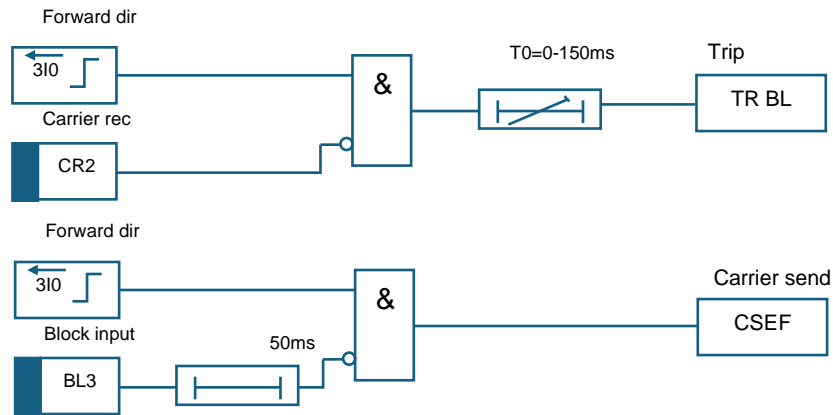

Figure 8. A blocking arrangement with directional ground fault relays

In most situations, the directional ground fault relays in a communication arrangement, also include a communication independent back-up tripping with a time delay. Inverse or definite time delay can be applied. Typically, the inverse characteristic and the logarithmic inverse characteristic give the best possibility to achieve time selectivity also at back-up tripping.

### Single Phase Tripping

In situations when distance protection relays with single phase tripping and auto reclosing are installed at the same line as an arrangement with ground fault relays, it needs to be ensured that the distance protection relays are allowed to operate first. Therefore, ground fault relays must be time delayed. This rule needs to be followed when communication arrangements are used. A blocking of the ground fault arrangement at distance protection operation is typically used to enable use of short time delays in the communicating ground fault relays. During a single phase trip an unbalance in the complete electrical network happens and an ground fault currents flows through the network.

These currents can reach levels up to 20% of the load current and an unnecessary tripping from ground fault relays can happen. Typically, ground fault relays are blocked during the single phase auto reclose cycle.

### Current Reversal

A special problem happens when directional earth fault schemes communicate in a POR arrangement. The problem is fault current reversal which happens when the CB at one end of the faulty line operates before the breaker at the other end. The fault current changes direction in the parallel line. Timing problem to prevent maloperation will happen (as shown in Figure 9). A special logic shown in Figure 10 is needed to prevent an unnecessary operation.

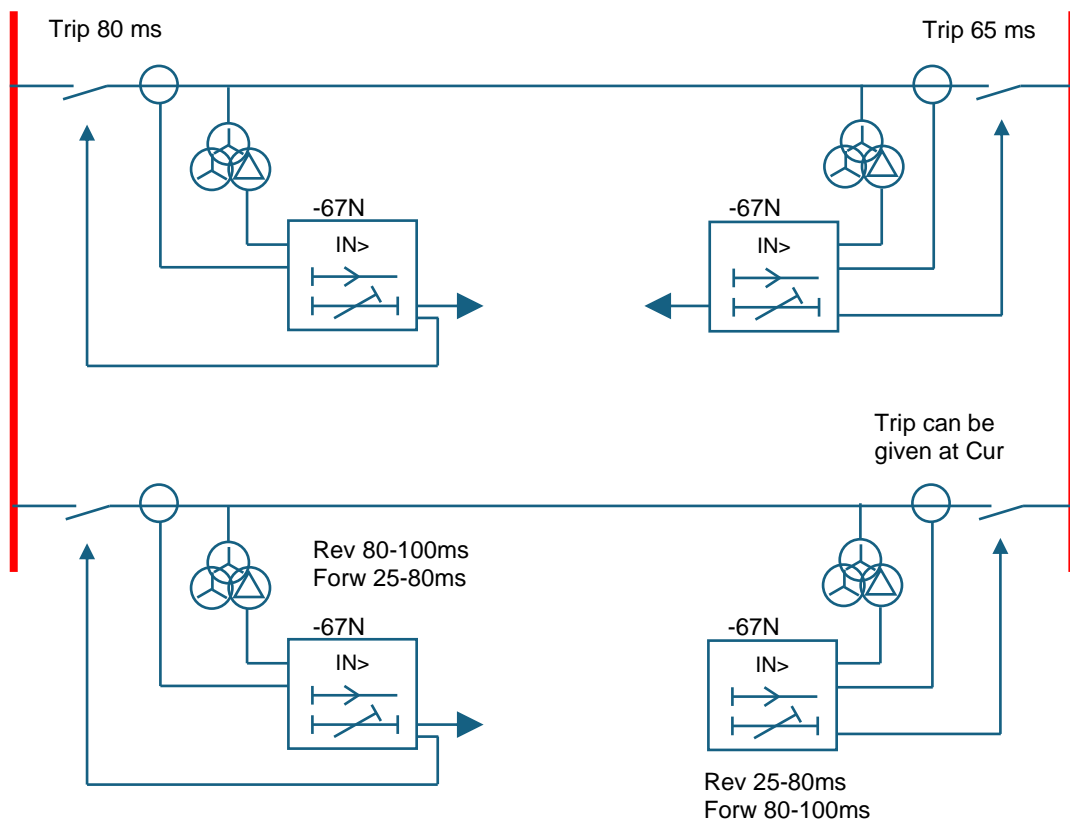

Figure 9. The current reversal problem in parallel feeders

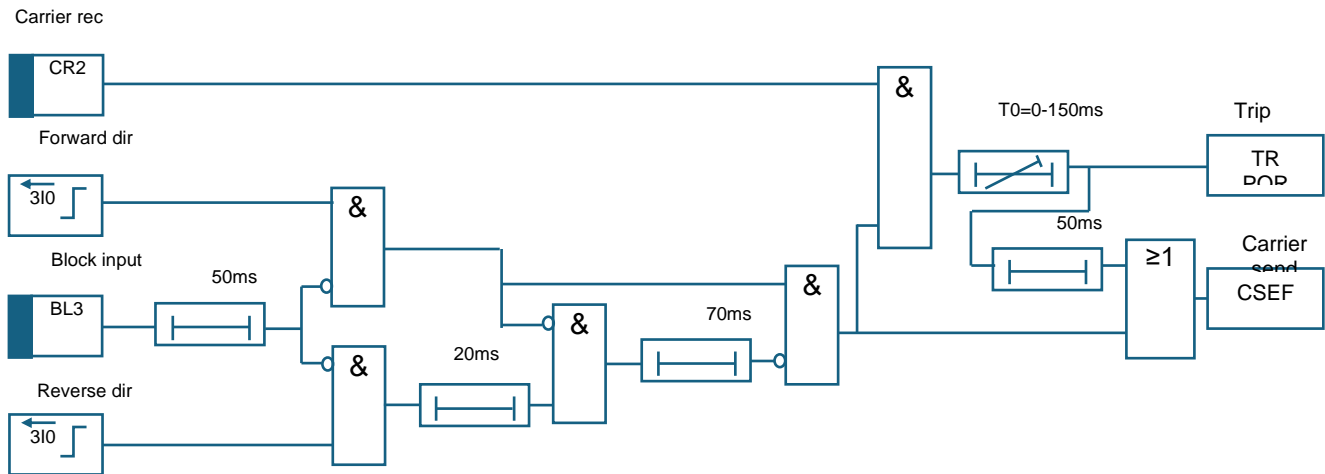

Figure 10. A logic in directional ground fault relays, to prevent unnecessary operation during current reversal

### Weak-end Infeed

In some situations, the fault current infeed from one end isn't ensured during certain service conditions. A special weak-end infeed logic can be used together with POR schemes. It is based on zero sequence voltage and the receipt of a carrier signal (CS) from the remote (strong) end. The logic for ground fault weak-end infeed function includes a check of UN voltage at carrier receipt. In that case, the breaker is tripped even if no operation of DEF relay is achieved due to a too weak source. It is also critical to "mirror" the carrier signal back, so the signal is sent back on receipt especially in the cases of low UN voltage, or in the case the circuit breaker is open.

### Inrush Current Stabilization

In some situations a second harmonic stabilization is needed for sensitive ground fault relays. This is needed due to inrush currents that happen during transformer energization which, in some networks lasts longer. Typically, the long durations are found in weak networks. The second harmonic stabilization can then block the ground fault relay, during the inrush and prevent the risk of an unnecessary operation. It has to be noted that a POR communication arrangement cannot operate for inrush currents as only one end will have fulfilled conditions whereas the other end will have a blocking

condition.

For inverse time delayed arrangement a time setting is chosen to accomplish selectivity to instantaneous protection. This provides a long delay in comparison to normal inrush times and the inverse characteristic will then match the decay of the inrush current and prevent relay from unwanted operation. Stabilization is only necessary is when very sensitive definite time delayed relays are installed. In those situations the inrush can cross the corner with minimum current before the time elapses and an unwanted function happens.

### **Reactance Grounded Systems**

The ground fault protection in a reactance grounded system is accomplished with a simple scheme since the fault current comes only from the source side of the network. The grounding is done at the feeding transformer or at the busbar through a Z-0 grounding transformer.

### **Z-0 Grounding Transformer**

The grounding transformer is chosen to give ground fault current with predefined level. Typically, the chosen current is 750 to 1500A. The Z-0 (zig-zag) transformer scheme is presented in Figure 11.

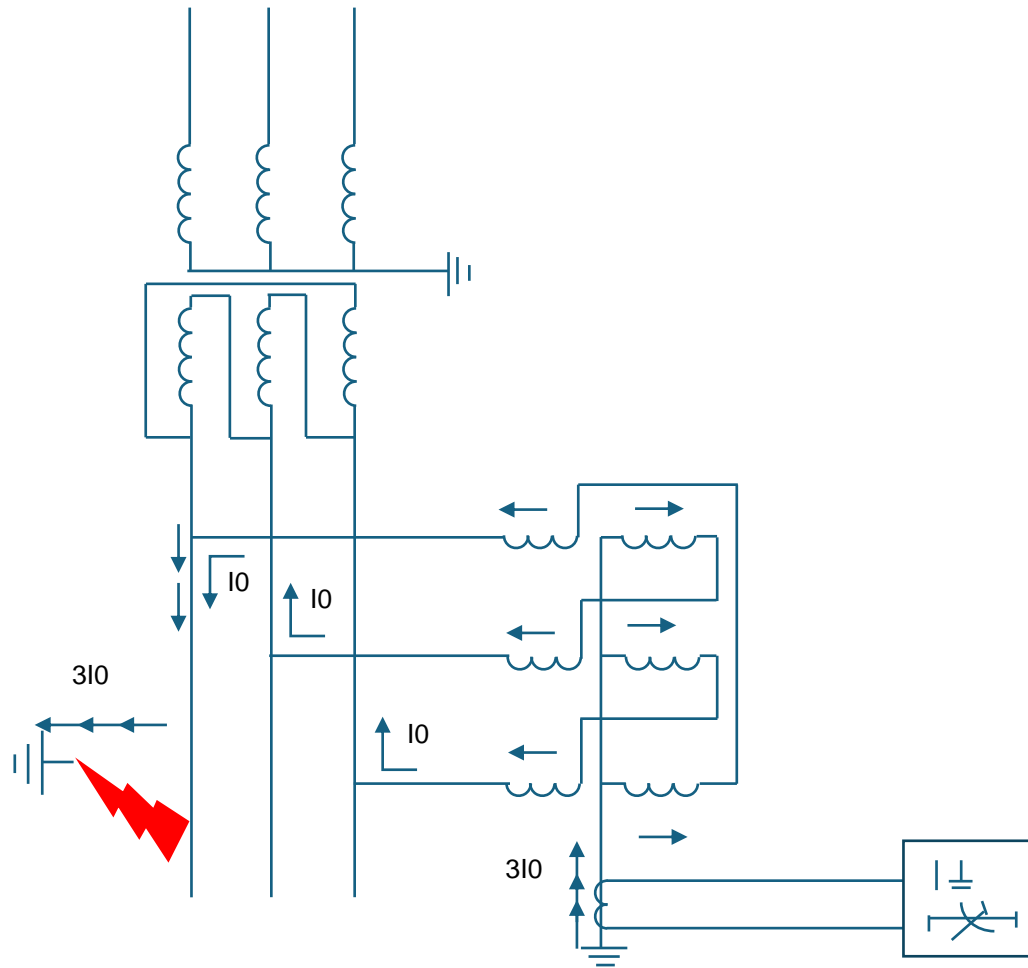

Figure 11. The Zig-zag transformer scheme providing ground fault current in a reactance grounded electrical system

The reactance is chosen to give the fault current. It needs to be kept in mind that the zero sequence reactance in  $\Omega/\text{phase}$  is three times the reactance calculated by the formula:

$$3I_0 \text{ for example } I_N = 1000A = \frac{U_n}{\sqrt{3} \times Z_N}$$

Respectively

$$\frac{U_n}{\sqrt{3} \times I_N} = Z_N$$

This implies that, for a 20kV system with 1000A grounding, the Z-0 transformer shall be

chosen with a zero sequence reactance which is calculated as follows:

$$X_0 = \frac{20}{\sqrt{3}} 1000 = 11.6 \rightarrow \text{Select } 35\Omega/\text{phase}$$

A Z-0 transformer can be equipped with an auxiliary power supply winding with a 400V secondary. This is possible up to 800 -1000kVA and the protection system have to be checked so that the proper fault protection of the low voltage side of the auxiliary transformer is accomplished. One possibility is to install delta connected short circuit protection at the HV side (Z-0 winding). Fuses and breakers installed at the HV side of a Z-0 transformer should be avoided as the network grounding can then be disconnected and the risk of ground fault trips disappears. It will also involve a risk of arcing faults and of ferro-resonance in the voltage transformers.

### **Fault Resistance and Fault Current Levels**

In a reactance grounded system the current is still considerably high. Therefore, the fault resistance will decrease and an initial fault will quickly, develop into a fault situation. The fault current magnitude will not depend on the fault position. If reactance grounding with 1000 A is used in a 20 kV system, the neutral reactance will be 12  $\Omega$ . This implies that a reactance to the fault, through a line of 12  $\Omega$ , will make the fault current level half (12  $\Omega$  will be the reactance of a 30km line in a 50 Hz system). If a fault resistance is introduced the resistance will add vectorial to the reactance and the current will change slowly with the fault resistance.

### **Voltage of the Neutral Point**

The neutral point voltage is determined in the same way as the source impedance. This implies that for a fully developed ground fault full neutral displacement happens and a fault current of 20%, for example 200 A in a 1000 A grounded system will be 20% of "Un".

## Restricted Earth Fault Protection

A Restricted Earth Fault (REF) protection cannot be justified in a reactance grounded system in the same way as in a solidly grounded system. This is because the fault current is much lower and therefore the damage which depends on the “ $I^2t$ ” condition. Nevertheless, in many systems REF protection relays are also used in reactance grounded systems. The connection of a REF relay in a reactance grounded system is presented in Figure 12.

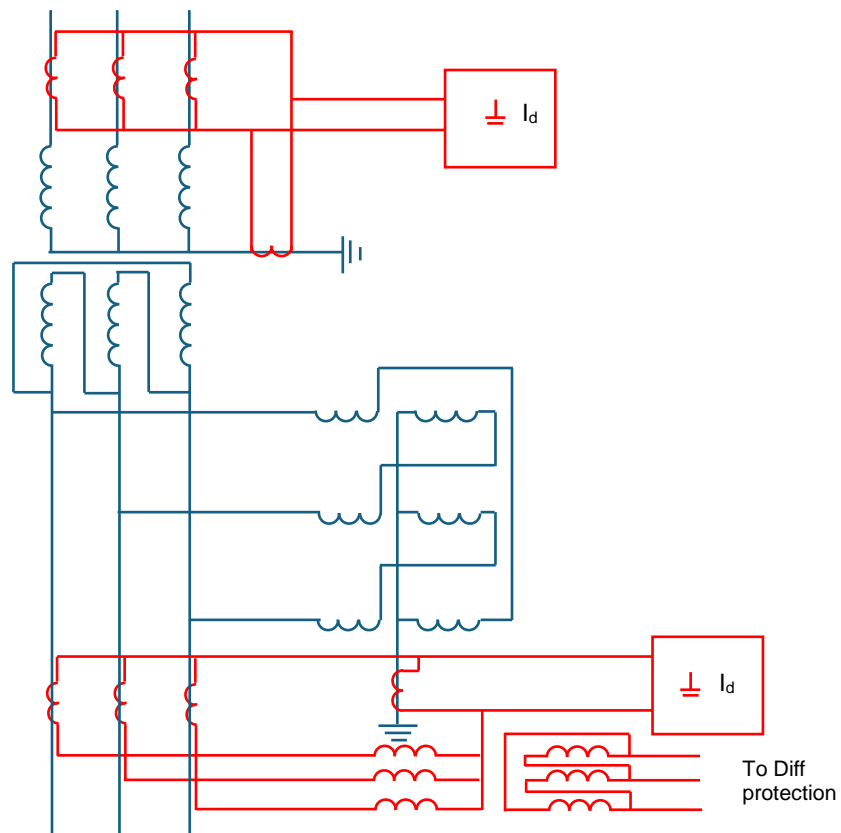

Figure 12. A Restricted Earth Fault (REF) relay in a reactance grounded system with a Z-0 transformer

The application is possible, but it needs to be ensured that a high sensitivity is accomplished. Operation values of 5-10% of the maximum ground fault current are needed. When the REF operating voltage is calculated the verification of required operating value needs to be done by first verifying the ground fault loops for phase CTs and neutral CTs. Nevertheless, as the maximum through fault current is limited by the reactance a verification of the occurring loop at phase faults needs to be done. The unbalanced voltage is caused by one phase CT which is saturated and the other is not. For instance, this can be caused by the DC components at fault current which is not equal between the phases. This verification will typically set the required operating voltage as the fault current at phase faults is much higher. It is useful to summate the three CTs as close to the current transformers as possible. Occasionally, this can be difficult because of the transformer differential relay and its interposing CT's are installed in the same circuit.

### **Earth Fault Protection**

The earth fault protection in a reactance grounded system is typically accomplished with time delayed simple and unidirectional ground fault current measuring relays. Protection time grading in the neutral of the zig-zag transformer is used. The time delay can be with normal inverse or definite time delay. An arrangement with inverse time delayed relay is presented in Figure 13.

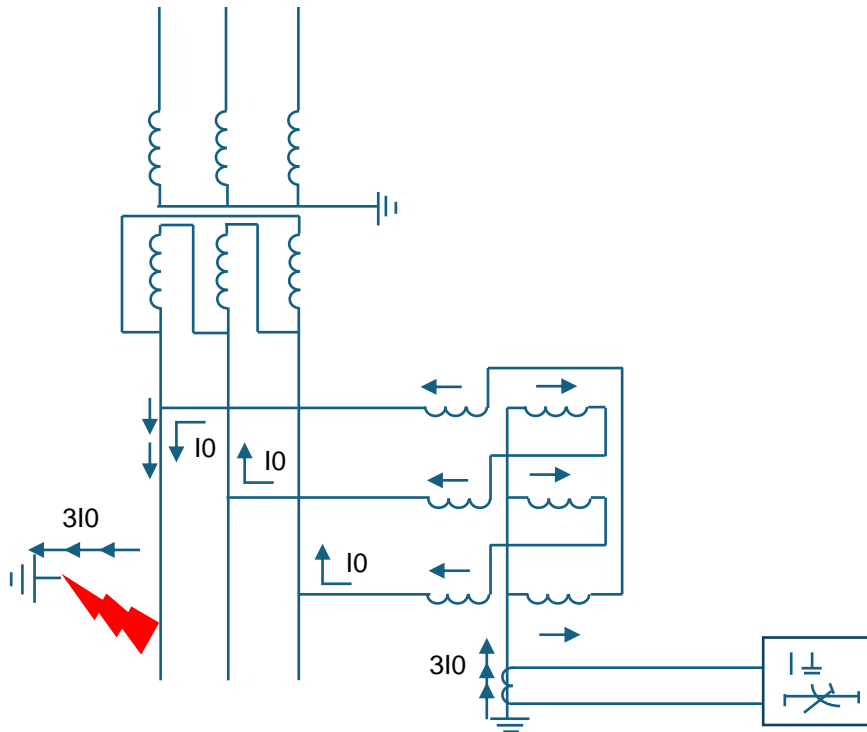

Figure 13. Ground fault protection system for a reactance grounded network where selectivity is accomplished with an inverse time delayed relays

### High Resistance Earthed Systems Arrangement

The high resistance grounded networks are grounded only at the source side of the network. Typically, the grounding is restricted to only one point and an arrangement allows different connection possibilities of the grounding point due to the service conditions. This arrangement is shown in Figure 14.

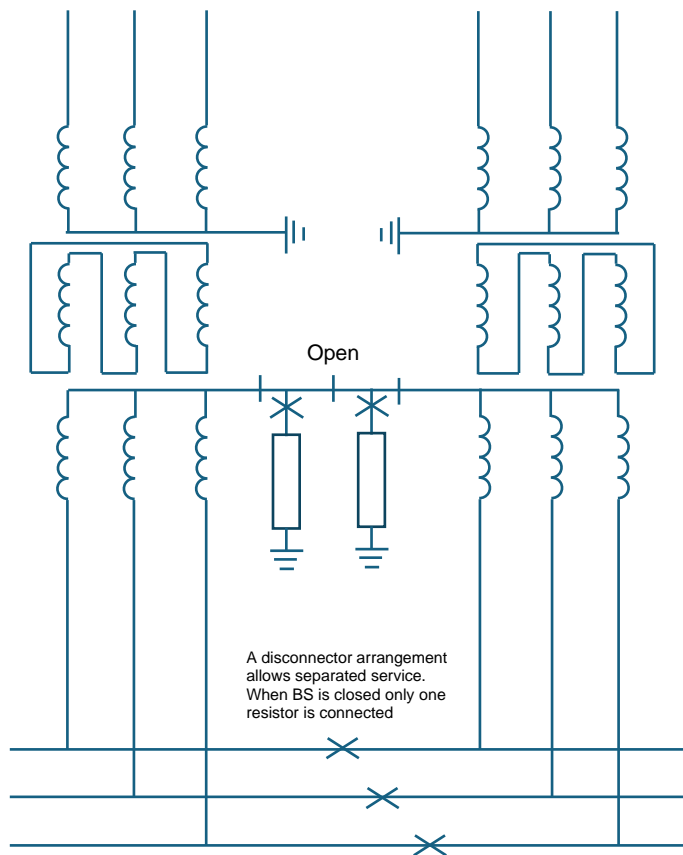

Figure 14. A high resistance grounded network and a selection of service conditions with disconnectors

### Fault Resistance and Fault Current Levels

The grounding resistor is typically set to give ground fault current of 5-15A. The trend to decrease the current level gives lower requirement of grounding grid and higher neutral point voltages at high resistive ground faults.

Due to the low current magnitude, high resistance ground faults will not quickly develop to lower resistance so a high fault resistance has to be detected. In order to detect such high values it is typically necessary to use a resonance grounding in order to accomplish reasonably high neutral point voltages ( $>5V$  at  $5000 \Omega$ ). Due to the high needed sensitivity it's required to use cable current transformers surrounding the three phases to complete the measuring. The current transformer is then chosen with a

suitable ratio independent of load current and no current will flow during normal operation. Sensitivity down to 1-2A primary is needed at high resistance grounded systems.

### **Voltage of the Neutral Point**

In order to sense high values of fault resistance (up to 5000  $\Omega$ ) it's typically required to use a resonance grounding to accomplish acceptable high neutral point voltages (>5V at 5000 $\Omega$ ). The neutral point voltage is needed to give the directional criteria for the directional ground fault protection and is also used to provide a back-up ground fault protection at the busbar or the transformer bay. A small neutral point voltage exists, during network normal operation due to unsymmetrical capacitance of the phases to ground and the resistive current leakage at apparatus such as surge arresters. Typically, the level of unbalance currents is around 0,2 - 5%. Therefore, neutral point detection relays and directional relays should never be allowed to have sensitivities below 5-10% to compare with the requirements of very low levels in solidly grounded electrical networks.

The neutral point voltages are calculated with the fault resistance " $R_f$ " connected in series with the neutral reactance " $Z_N$ ". The neutral impedance consists of the grounding resistance " $R_N$ " and the network capacitive reactance " $X_C$ ". The " $Z_N$ " impedance can be calculated as " $U_n/(xI_f)$ ", where  $I_f$  is the total fault current. It needs to be remembered that " $Z_N$ ", as well as the vectorial sum have to be calculated.

### **Directional Earth Fault Protection**

Due to capacitive current infeed from healthy objects during ground fault it's typically needed to use directional earth fault relays. Directional relays are used when the capacitive current infeed from an object in other object is higher than 60% of the required sensitivity.

The directional relays will only measure the active component of the fault current, for example the current generated by the grounding resistance. The principle for fault

current and capacitive current generation is presented in Figure 15.

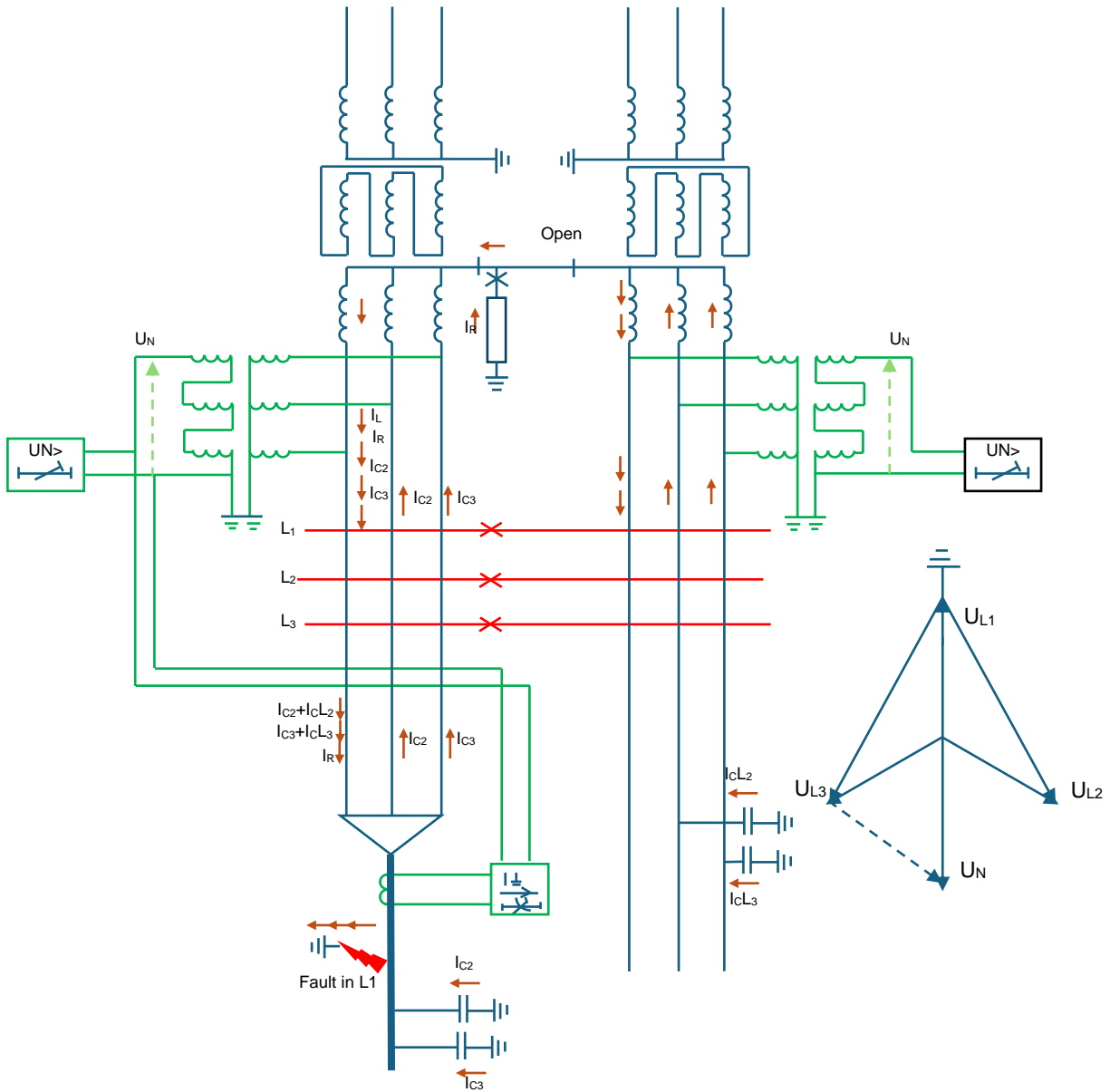

Figure 15. The fault and capacitive current distribution in a high resistance grounded network

## Efficiency Factor Calculation

The efficiency factor needs to be determined when sensitive ground fault relays are installed.

## Resonance Earthed System Arrangements

The resonance earthed networks are only grounded at the source side of the network. Typically, the grounding is restricted to only one point, or two with parallel transformers, and an arrangement is provided to allow connection with the grounding point. Arrangement changes with the service conditions. The grounding consists of a tapped reactor tuned to the network capacitance compensating the current and gives a fault current close to zero at the fault location. In many situations a high value resistor is installed in parallel to generate a resistive fault current that can be measured by the protection system.

Alternatives without this type of resistor and with transient measuring relays are also used. Figure 16 presents the grounding principle and the flow of ground fault current components.

## Fault Resistance and Fault Current Levels

The grounding resistor is typically set to give ground fault current of 5-15A. The trend to decrease the current level gives lower requirement of grounding grid and higher neutral point voltages at high resistive ground faults.

Due to the low current magnitude, high resistance ground faults will not quickly turn into low resistance. This implies that a high fault resistance has to be detected. For overhead lines the value for detection is 3000  $\Omega$ . In order to sense these high values it's typically necessary to use a resonance grounding to accomplish acceptable high neutral point voltages (>5V at 5000 $\Omega$ ).

Due to the high sensitivity needed it's beneficial to use cable current transformers

surrounding the three phases in order to complete the measuring. The current transformer is chosen, with an appropriate ratio independent of load current, and no current will run during normal operation.

Sensitivity below 1A primary is needed with resonance grounded systems.

### **Voltage of the Neutral Point**

In order to sense high values of fault resistance, up to 5000  $\Omega$ , it's typically necessary to use a resonance grounding to accomplish acceptable high neutral point voltages ( $>5V$  at 5000  $\Omega$ ). The neutral point voltage is needed to give the directional criteria for the directional ground fault protection and is also used to provide a back-up ground fault protection at the busbar or the transformer bay.

A small neutral point voltage exists, during normal network operation, due to unsymmetrical capacitance of the phases to ground and current leakage at equipment such as surge arresters. Typically, unbalance current level is around 0,2 - 5%. Therefore, neutral point detection relays and directional relays should never be allowed to have sensitivities below 5-10%.

The neutral point voltages are computed with the fault resistance " $R_f$ ", in series with the neutral reactance " $Z_N$ ". The neutral impedance consists of the grounding resistance " $R_N$ ", the network capacitive reactance " $X_C$ " and the reactance of the grounding reactor (typically tuned, " $X_L$ "). The factor " $R_f/(R_f+Z_N)$ " gives per unit voltage. The " $Z_N$ " impedance can be calculated as " $U_n/(xI_f)$ ", where  $I_f$  is the total fault current. It has to be kept in mind that " $Z_N$ ", as well as the vectorial sum have to be determined. This implies that the capacitive and reactive components " $X_C$ " and " $X_L$ " are in opposition and typically will end up close to zero. This means that the fault current is lower and the overall reactance also will be close to zero.

### **Directional Earth Fault Protection**

Due to capacitive currents infeed, during ground fault, it's typically needed to use

directional ground fault relays. Directional relays are used when the infeed of capacitive current in other object, is higher than 60% of the needed sensitivity.

The directional relays will only measure the active component of the fault current for example the current generated by the grounding resistance (the principle for fault current and capacitive current generation is presented in Figure 16).

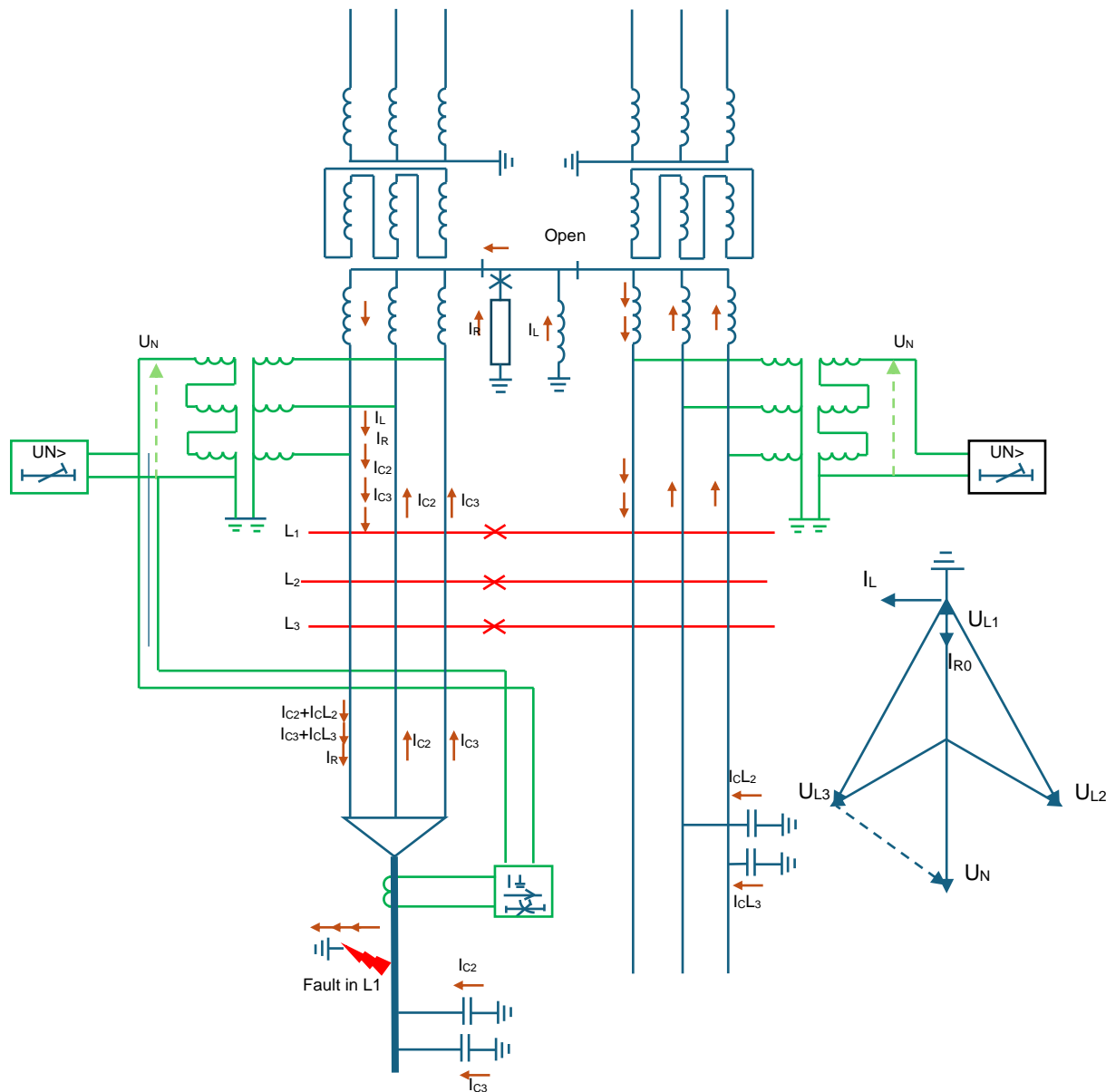

Figure 16. A directional ground fault relay on a resonance grounded system

## Neutral Point Control

This method includes a neutral point control, where the unsymmetrical voltage in the neutral during normal operation is measured, and compensated for in all phases by reactive components. The grounding is arranged with a neutral reactor in combination with a movable core. This core is able to permanently regulate the reactance and compensate capacitive current in the network. The unsymmetry due to unsymmetrical capacitances at the different phases to ground, as displayed in Figure 14, will create a neutral point voltage. This voltage can be compensated in different ways but phase-wise reactor/resistors as presented in Figure 15, will enable regulation and unbalance compensation. This implies that the neutral point voltage during normal operation is zero.

Ground fault currents down to tenth of an ampere can be achieved and it is possible to have the network in operation during ground fault until it is convenient to take the line out of service for maintenance.

In this case, ground fault protection must be arranged, based on other principles than measuring of fundamental ground fault currents. A transient measuring relay as presented below is one possible solution.

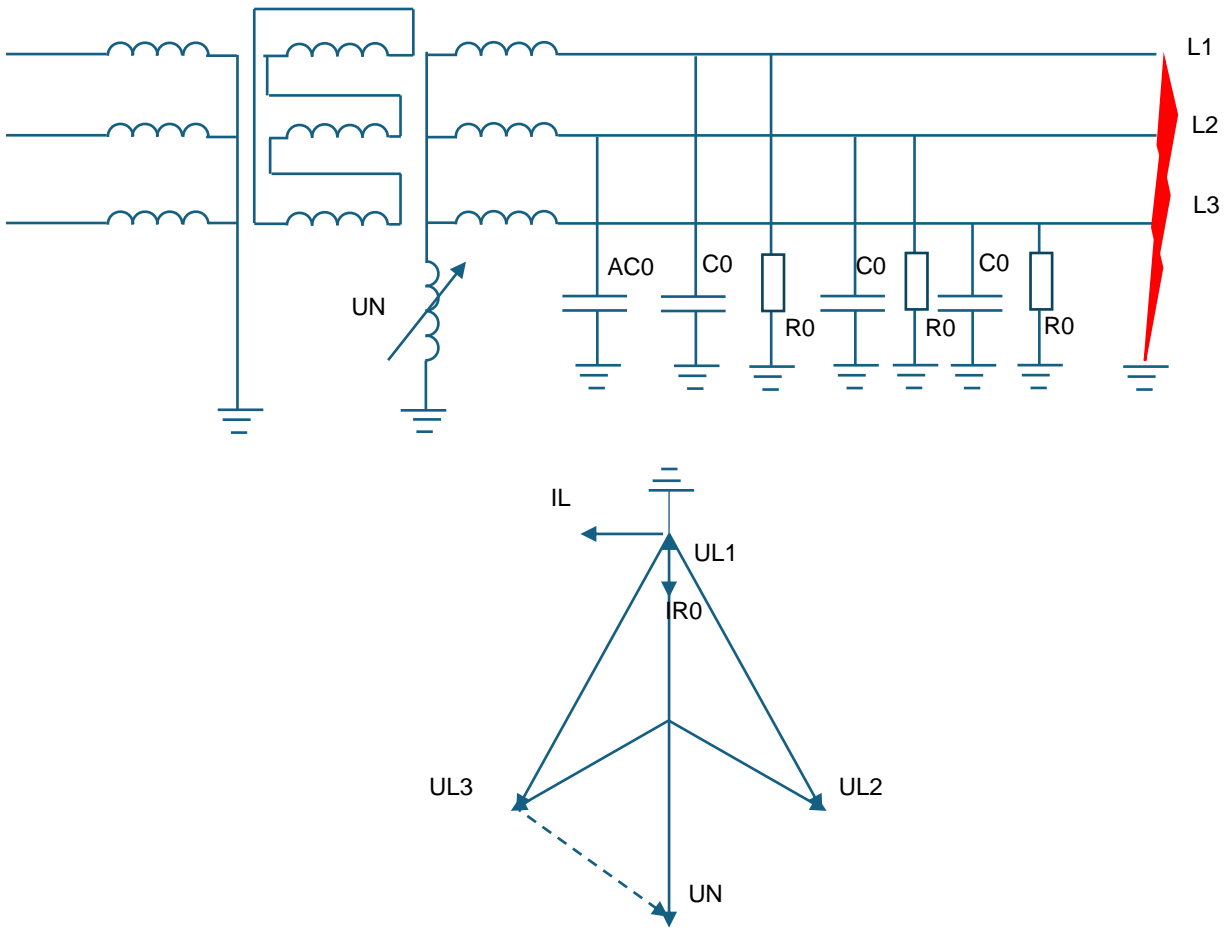

Figure 17. Unsymmetrical capacitances giving neutral point voltages during normal operation

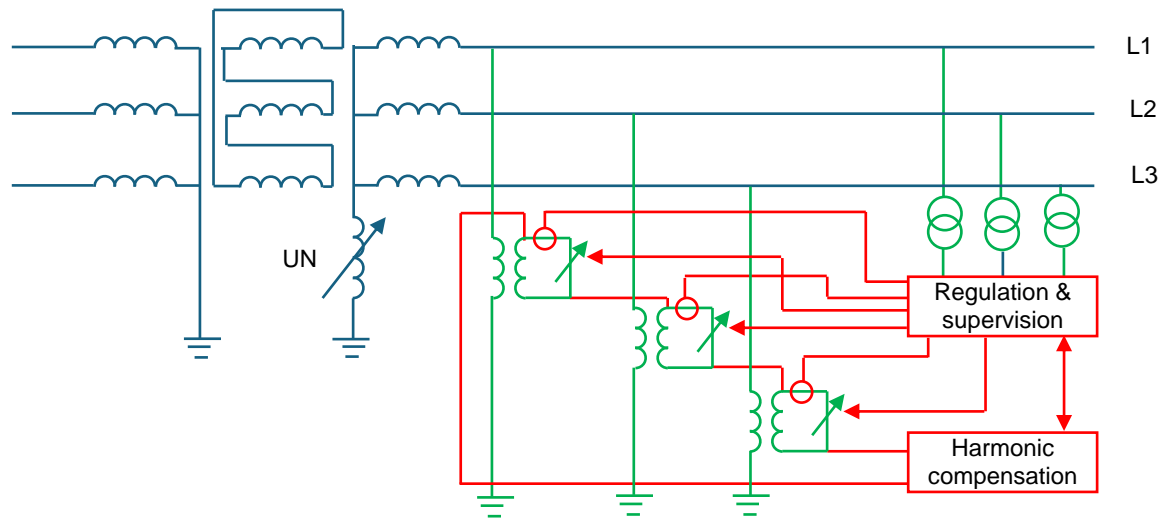

Figure 18. Compensation equipment for neutral point unsymmetry

### Transient Measuring Relays

In the high resistive, resonance and ungrounded electrical network, ground fault measuring based on the transient occurring at ground fault location can be used. The transient is caused by the sudden voltage change and the sudden inrush of capacitive currents into the healthy phases of the feeders.

This current can be measured with a residual sum measurement or with cable current transformers. The transients have frequency ranging from 100 Hz to 5000 Hz. It is damped out very quickly, typically within the first half cycle after the fault as shown in Figure 19. Therefore, the measurement is combined with a neutral point voltage measurement and the relay will seal-in the direction of the transient as long as the neutral point voltage is available.

Forward and reversed direction can be discovered by the transient direction. For resonance grounded networks, transient measuring relays can be set to be sensitive to high resistive ground faults if no resistor is used, since the neutral point voltages will be high.

The transient in the current does not depend on the neutral device as this is caused by the transient voltage change.

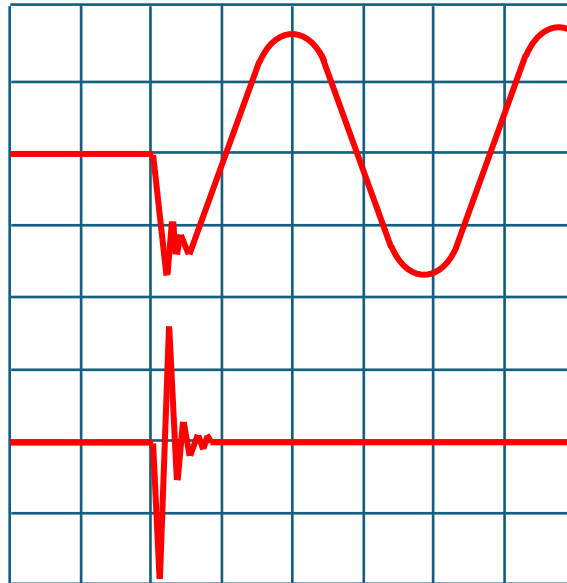

Figure 19. The neutral point voltages and the high frequency transient occurring at ground fault location

### Measuring Earth Fault Current

In the case of the ground faults in a three phase system the residual sum of the three phase currents will not end up to zero as during normal operation. The ground fault current can be measured by a summation of the three phase currents. The summation can either be done by a summation of the three phase current transformers, in a residual sum connection or by a cable current transformer surrounding the three phase conductors. These options are presented in the Figure 20.

### Residual Sum Connected Current Transformers

In the case a residual sum connection is used a residual current can be achieved. It is caused by the small differences between the current transformers in the three phases.

The residual current can reach high values, particularly during a short circuit. This can push high sensitivity ground fault relays to operate. To prevent ground fault relay operation a release of ground fault relay by a neutral point voltage protection and/or a blocking of the ground fault relay at operation of an overcurrent protection should be done.

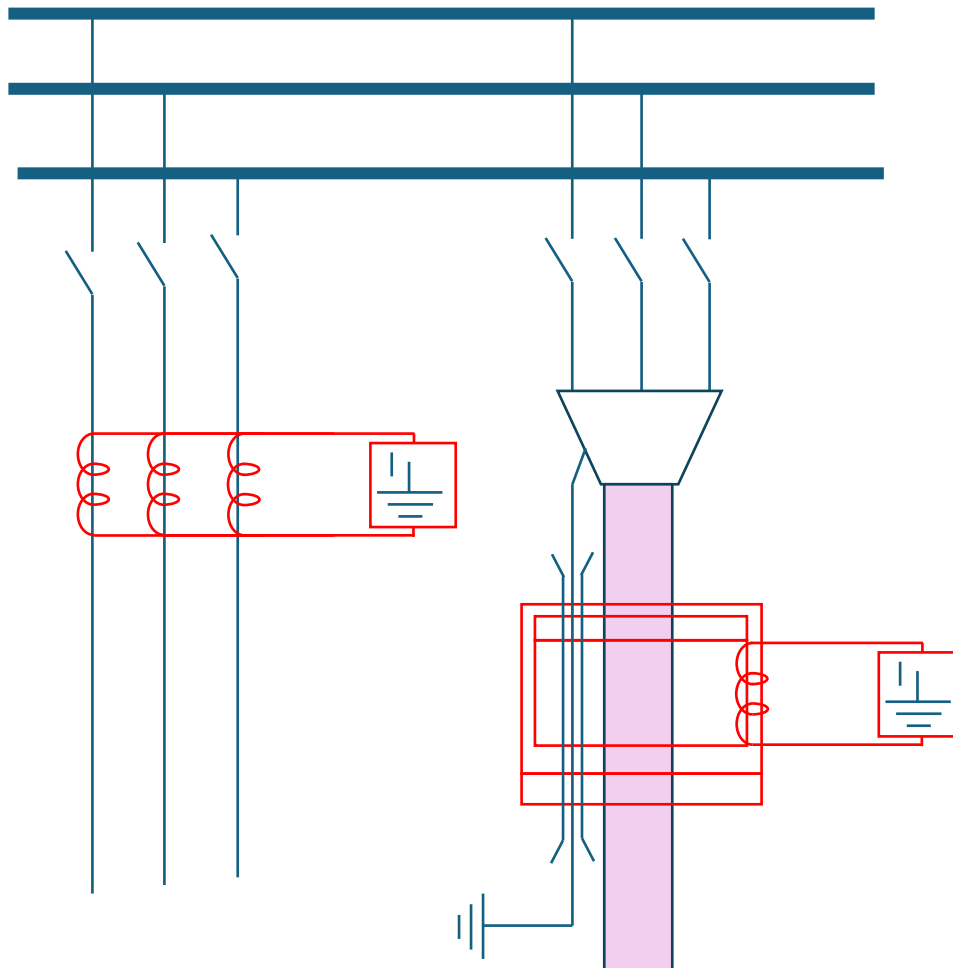

Figure 20. Ground fault current measurement can be done with a residual sum measurement of a cable CT that's surrounds all three phases

Considerably higher sensitivity can be achieved with cable current transformers than with residual connected phase current transformers since the current ratio can be freely chosen. In the residual connected case the current transformers are given a ratio above the maximum load currents.

For reactance and solidly grounded systems this is not mandatory due to the low sensitivity of the ground fault protection.

### **Cable Current Transformer**

Cable current transformers are available in different types with different mounting methods, different ratios and for different cable diameters. Epoxy quartz transformers must be thread onto the cable end before the cable box is installed. Transformers with openable cores can be installed after mounting of the cables is completed.

Different ratios are used. Today 150/5 and 100/1A is typical whereas 200/1A has been a typical figure in past. A much higher sensitivity can be accomplished with cable current transformers than with residual connected phase current transformers since the current ratio can be freely chosen. When residual connected the current transformers are given a ratio higher than the maximum load currents.

For reactance and solidly grounded network this is not mandatory due to the low sensitivity of the ground fault protection. The ground fault protection relays setting range must be chosen together with the current transformer ratio to give the necessary primary sensitivity.

### **Cable Current Transformer Mounting**

In order to accomplish a correct measurement the cable sealing end must be insulated from ground and the cable screen grounding needs to be done as shown in Figure 20. The current in the cable screen will then be in opposite direction to the current in the grounding connection. Therefore, it will not be measured. Hence, the fault current going out to the fault is the only current to be measured.

The cable must be centralized in the hole of the transformer in order to prevent unbalance currents. Typically, cables are grounded at one end only if they are single-phased. This is done to prevent the load current causing an induced current flowing in the screen/armory. In the case cables are three phase one-or two ends can be grounded.

### **Earth Fault Relay Sensitivity**

When the primary ground fault current “3I<sub>0</sub>” is transformed in the residual sum connected current transformers or in the cable current transformer a part of the current is used to magnetize the current transformers to the terminal voltage “U” which is required to achieve the relay operating current.

The phase angle needs to be considered at efficiency factor “η” calculation:

$$\eta = \frac{I_{set}}{3I_0 \times n}$$

where “I<sub>set</sub>” is the set value of the ground fault relay, “3I<sub>0</sub>” is the primary ground fault current and “n” is the current transformer turns ratio.

# Earth Fault Protection - Quiz

Updated: 1/7/2025

1. The fault resistance depends on \_\_\_\_\_.
  - a. Arc resistance
  - b. Tower foot resistance
  - c. All of the above
  - d. None of the above
  
2. Neutral point voltage is created by the ground fault current " $I_0$ " through the \_\_\_\_\_.
  - a. Zero sequence source
  - b. Zero sequence impedance
  - c. All of the above
  - d. None of the above
  
3. Neutral point voltage will be very low when sensitive ground fault relays are installed in a strong network with low zero sequence source impedances.
  - a. True
  - b. False
  
4. One of the major advantages of the \_\_\_\_\_ relays is their high sensitivity.
  - a. Restricted earth fault
  - b. Sensitive directional ground fault
  - c. All of the above
  - d. None of the above

- 5. Restricted earth fault sensitivity depends on the \_\_\_\_\_.**
- a. Current transformers accuracy class
  - b. Current transformers magnetizing currents
  - c. Voltage transformer accuracy class
  - d. Type of the used restricted earth fault relay
- 6. Restricted earth fault relays are very fast due to measurement of only one winding.**
- a. True
  - b. False
- 7. It is common practice to install the restricted earth fault relay in the same current circuit as the \_\_\_\_\_.**
- a. Sensitive directional ground fault relay
  - b. Transformer differential relay
  - c. All of the above
  - d. None of the above
- 8. The \_\_\_\_\_ can block the ground fault relay, during the inrush and prevent the risk of an unnecessary operation.**
- a. Second harmonic stabilization
  - b. Third harmonic stabilization
  - c. All of the above
  - d. None of the above

**9. Operation values of \_\_\_\_\_ of the maximum ground fault current are needed for restricted earth fault protection in the reactance grounded networks.**

- a. 5-15%
- b. 5-10%
- c. 1-5%
- d. 2-8%

**10. In the case of a high resistance grounded networks, the grounding resistor is typically set to give ground fault current of \_\_\_\_\_.**

- a. 5-10A
- b. 1-5A
- c. 10-20A
- d. 5-15A

**11. \_\_\_\_\_ should never be allowed to have sensitivities below 5-10%.**

- a. Neutral point detection relays
- b. Directional relays
- c. All of the above
- d. None of the above

**12. Directional relays are used when the capacitive current infeed from an object in other object is higher than \_\_\_\_\_ of the required sensitivity.**

- a. 60%
- b. 50%
- c. 40%
- d. 70%