

Arc Flash Resistant Equipment



Arc Flash Resistant Equipment

By

Velimir Lackovic, Electrical Engineer

PDHLibrary Course No 2025013
2 PDH HOURS

Arc Flash Resistant Equipment

Arc flash resistant equipment may be described as the equipment made to withstand the impact of internal arcing fault by meeting the testing requirements of IEEE Guide C37.20.7-2007. In the 1970s, an interest started in Europe in assessing electrical equipment under internal arcing, which led to IEC standard. This research spread to North America and was used as a foundation for EEMAC G14-1 procedure. The development of IEEE standard heavily relies on Annex AA of IEC standard and adopts many of the refinements originated in EEMAC G14-1 procedure. IEC 62271 - 200 defines the requirements for factory assembled metal - enclosed switchgear and control gear for alternating currents at rated voltage above 1 kV and up to and including 52 kV. It includes indoor and outdoor assemblies and frequencies up to and including 60 Hz. The arc - resistant construction can be used for:

- Medium voltage switchgear
- Low voltage switchgears
- Medium voltage MCCs
- Low voltage MCCs.

ARC FLASH HAZARD CALCULATION IN ARC-RESISTANT DEVICES

It is well known that even if arc-resistant devices are used, additional power system protection, like AFD and differential protection systems, need to be provided to decrease the arcing time and incident energy release. The computation of incident energy, hazard risk category and PPE category for arc-resistant devices and their reductions uses the same methodology as for typical electrical equipment.

Arcing Fault Probability

There is little probability of an internal arc in devices meeting the demands of IEEE C37.20., C37.20.2 and C37.20.3 - 2001, which cover metal-clad and metal-enclosed switchgear though the possibility cannot be completely eliminated. There is even lower probability of an internal arc in devices that has insulated bus, barriers, compartmentalization and interlocks, for instance, metal-clad switchgear. If doors or panels are opened for maintenance, which are not supposed to be opened, the devices are no longer arc resistant. Depending upon the construction and testing, it is possible to open the low voltage enclosure of arc-resistant switchgear, without affecting the arc-resistant nature of the equipment. However, all maintenance work cannot be completed simply because devices are arc resistant. NFPA 70E standard defines hazard risk category of 4 for the arc-resistant switchgear, type 1 or 2, with clearing time lower than 0.5 seconds for insertion or removal of circuit breaker from cubicles with opened door. However, this situation has to be assessed on a case by case basis depending upon the protection and system short circuit current levels. Sometimes, the circuit breakers will be locally taken out in modern work environment. Industrial systems are resorting to remote racking, and the staff presence near the device is not needed except to engage the remote racking system. Hence, arc-resistant devices are no longer arc resistant if any doors or panels are opened, which are not supposed to be opened. As long as panels or doors are not opened, the arc flash risk outside the equipment can be conceived zero. Some arc flash hazard does exist around conventional devices with the door closed. NFPA committee states that: "Normal service of the enclosed electrical devices, working at 600 V or less, that has been adequately installed and maintained by qualified staff is not likely to expose the staff to an electrical hazard". Hence, a question comes up if it is necessary to spend 20–40% more capital outlay for arc- resistant devices. In Europe, the stress has been on arc containment and protection. In North America, the effort has been put to decrease the arc flash hazard by system innovation and protection systems rather than reinforcing the devices to withstand the internal arcing faults.

IEEE GUIDE QUALIFICATIONS

IEEE guide says that a guide cannot mandate or determine device ratings. A standard defines necessary requirements and performance levels that must be reached, checked, and tested for. A guide gives suggestions and rules, leaving performance levels to the end user and manufacturer. IEEE guide states that such devices cannot ensure overall staff protection under all circumstances that may exist at the time of internal arcing fault. It also clarifies that it is not supposed to give extra degree of protection to operational staff, who in the typical performance of their duties would be asked to alter the equipment from its normal working conditions. Staff activities or installation conditions not addressed include:

- Staff on top of switchgear
- Any activity that demands staff to be elevated above switchgear base level, that is, use of a ladder or lift
- Switchgear placed on an open grating
- Installations over a cable vault big enough for staff to enter the vault
- Equipment selection according to the guide does not imply protection from device damage or ensure continued operation without disruption of continued electrical service.

Since the typical devices are not arc resistant, a closed door or panel can shatter and release the arc flash products, causing staff injury who, happens to be in the vicinity of the energized device. Even though this eventuality may be small, it cannot be completely eliminated. With all defined limitations for arc-resistant devices, the incident energy outside an arc-resistant container is zero, as long as it is operated as per the test conditions. No extra PPE is needed for the staff presence in the vicinity of the arc-resistant device. In other words, if an electrical room has all arc-resistant devices, an operator can complete visual inspection, go around the devices, take meter readings, or even open low voltage containers, depending upon the arc-resistant design and testing.

ACCESSIBILITY TYPES

The IEEE Guide [1] accessibility types are the following.

Type 1

This equipment type considers switchgear with arc-resistant design and features at the freely accessible front of the equipment only.

Type 2

This equipment type considers switchgear with arc-resistant design and features at the freely accessible exterior (front back and sides) of the equipment only. The accessibility is assigned by choosing the type (either type 1 or type 2) and by adding an adequate suffix to designate the proper performance tested. For the basic presented tests, a suffix A is used, that is, type 1A or 2A, to present the basic rating. The other suffixes are described below.

Suffix B

This presents devices where normal operation involves opening the doors or cover of the containers, particularly identified as low voltage, control, or instrumentation containers. Testing methodologies that are not reproduced here are described for this suffix. The suffixes will be 1B or 2B. Suffix 1B states that the arcing does not create holes in the freely accessible front of the container or in the walls isolating the low voltage control or instrument areas. Suffix 2B states that the arcing does not create holes in the freely accessible front, sides, and rear of the container or in the walls isolating the low voltage control or instrument areas. Smoke entrance in the container under evaluation is allowable. Deformations of internal container walls, without signs of burning from a direct arc strike, that is, a hole, or opening in the walls, that is, torn seams are not the cause of device damage. Meeting the

demands of this assessment additionally qualifies the device for installation of instrument and control elements on the door or cover of the container tested without retesting the switchgear for the condition where the door or cover is present with elements installed on it.

Suffix C

This suffix presents devices where isolation from effects of an internal fault is desired between all adjacent compartments within a switchgear installation. This does not mean that devices may be operated with doors, covers, or panels opened. Suffix C designation cannot be applied to devices using open bus or open frame arrangement. The suffix 1C means that the arcing does not create holes in freely accessible front of the container or in the walls separating the compartments in which arc is started from all adjacent compartments. The suffix 2C means that the arcing does not create holes in the freely accessible front, sides, and rear of the container or in the walls separating the compartments in which arc is started from all adjacent compartments. The exclusion is that in a metal-clad arrangement, a fault in the main bus bar container of the vertical section is allowed to spread into the main bus bar container of the adjacent section, if the bus bars are in the same circuit, but not if the bus bars are in the different circuits. This demands further clarification. If the switchgear is of metal-enclosed arrangement or non-segregated design, an arc flash occurrence can spread within the container, and the only protection is pressure relief vents. In metal-clad arrangement, the protection is kept because all containers are block segregated and can hold created arc energy to that zone. The four zones are:

- Main bus zone
- Fused contactor zone
- Power cable zone
- Low voltage zone

Nevertheless, this does not mean that there will be no pressure vents.

Suffix D

This suffix presents the devices made for installations where some external surfaces of devices are inaccessible and there is no need to use a type 2 arrangement. Hence, this suffix is only applicable for accessibility type 1. The arcing does not create holes in the freely accessible front and any other surface under evaluation of the enclosure. The evaluated surfaces need to be mentioned on nameplate:

- SR, right side
- SL, left side
- R, rear

For instance, the designation can be Type 1D-SR. Extra tests are applicable for the suffixes. The manufacturer needs to define a minimum spacing between the room walls and the devices. A minimum ceiling distance shall also be defined, even if an external exhaust system is installed.

IEC ACCESSIBILITY TYPES

IEC standard describes Internal ARC Classification (IAC), which provides allowance for overpressure acting on doors, covers, inspection windows, etc.

- Type A. Limited to only authorized staff.
- Type B. Unrestricted accessibility, including that of general public.

The IEC accessibility types are for devices produced according to IEC specifications, for instance, IEC applies to the MCCs produced in line with IEC 61439. These are not interchangeable with the devices produced in line with ANSI/IEEE and NEMA specifications.

ARC-RESISTANT RATINGS

Arc - resistant ratings can be determined by two procedures. These are presented in the following paragraphs.

Duration Ratings

These are based on device rating to withstand an internal arcing fault for the specific duration. The maximum system voltage and maximum available prospective three- line short circuit current are part of the duration rating. This methodology gives the user more flexibility in choosing the protective relaying arrangements and making sure that the short circuit currents are cleared within the arc duration rating. The selection of the upstream circuit breaker is still very important, and an arc flash assessment and protection relay coordination study is needed to find out the arcing current levels and the arcing time. A short circuit on the main breaker itself, when installed in the arc-resistant equipment, will be cleared by an upstream breaker. If this circuit breaker is included in the differential relaying arrangement or AFD protection zone, including the incoming cable connections and circuits, then the arc flash time duration can be decreased consistent with the protection. But if the time–current coordination is relied upon to resolve the fault in the arc-resistant rated device, the extended arcing time withstands may be needed.

IEEE guide defines a favored rating of 0.5 second. With AFD or differential protection arrangements covering the entire arc-resistant device, the time duration can be decreased. It has much effect on the device price. The following considerations are applicable:

- It may be more economical and safe to include high-speed relay protection and decrease the arc withstand time, than to make device with higher arc withstand times.
- The greater is the arc fault current and the longer is its duration, the more robust the device needs to be. The internal damage to the device will be greater with greater arc withstand times.
- With greater arcing times, it will be necessary to substitute or refurbish a bigger part of the device after an arc fault event.

The process downtime is additional consideration. Such devices need to have a name plate indicating:

- Accessibility type
- Tested arcing short-circuit current, kA rms
- Arc duration, ms

Device-Limited Ratings

The device-limited ratings are based upon the internal arcing fault being limited by a specific element. The location of the element is crucial, for instance, a current limiting fuse will only limit the energy downstream of it. The protection is dependent upon the function of protective equipment. Therefore, the protection element needs to be reliable and comply with industry regulations.

The application will comply with the requirements, so long as:

- The system voltage does not surpass the tested voltage.
- The short - circuit current does not surpass the tested current.
- The special device type and the settings are used.

The device types may be:

1. Current limiting fuses
2. Fast operation circuit breakers
3. Typical circuit breakers with trip programmers
4. Special overcurrent protection relays with recommended settings
5. Extra testing is needed for current limiting devices as the special performance may differ under different circuit conditions.

Example

This example presents the principle behind equipment - limited ratings and may not be construed to apply to any special case. Consider four elements for 480-V three-phase 60-Hz applications:

- 600 - A class J fuse
- 2000 - A class L fuse
- 600 - A MCCB, thermal magnetic trip, magnetic pickup set at 3000 A.
- 2000 - A LVPCB, with electronic trip programmer

The characteristics of these elements are presented in Figure 1.

Figure 2 presents the incident energy release of these four elements as the bolted three-phase short-circuit current is changed from, 5–100 kA. The computations are done in line with IEEE Guide 1584, with a gap of 25 mm and working distance of 455 mm. Detailed step-by-step results are not shown, and the plots in Figure 2 show the ultimate incident energy calculations in cal/cm². The following conclusions are of interest:

- The incident energy release of a 2000 - A class L current limiting fuse stays above 40 cal/cm² (extreme risk). At low levels of short - circuit currents, for example at 10 kA, the incident energy release is higher than 1000 cal/cm². Hence, this fuse rating and type is not suitable for any low voltage system energy limitation.
- The 2000 - A LVPCB incident energy release goes to PPE level 2 for short-circuit currents, roughly > 46 kA. By selecting a much lower instantaneous setting, the situation can be made better, even though coordination with other overcurrent elements has to be simultaneously considered.
- The 600 - A MCCB and 600 A class J fuse provide much decreased incident energy release.

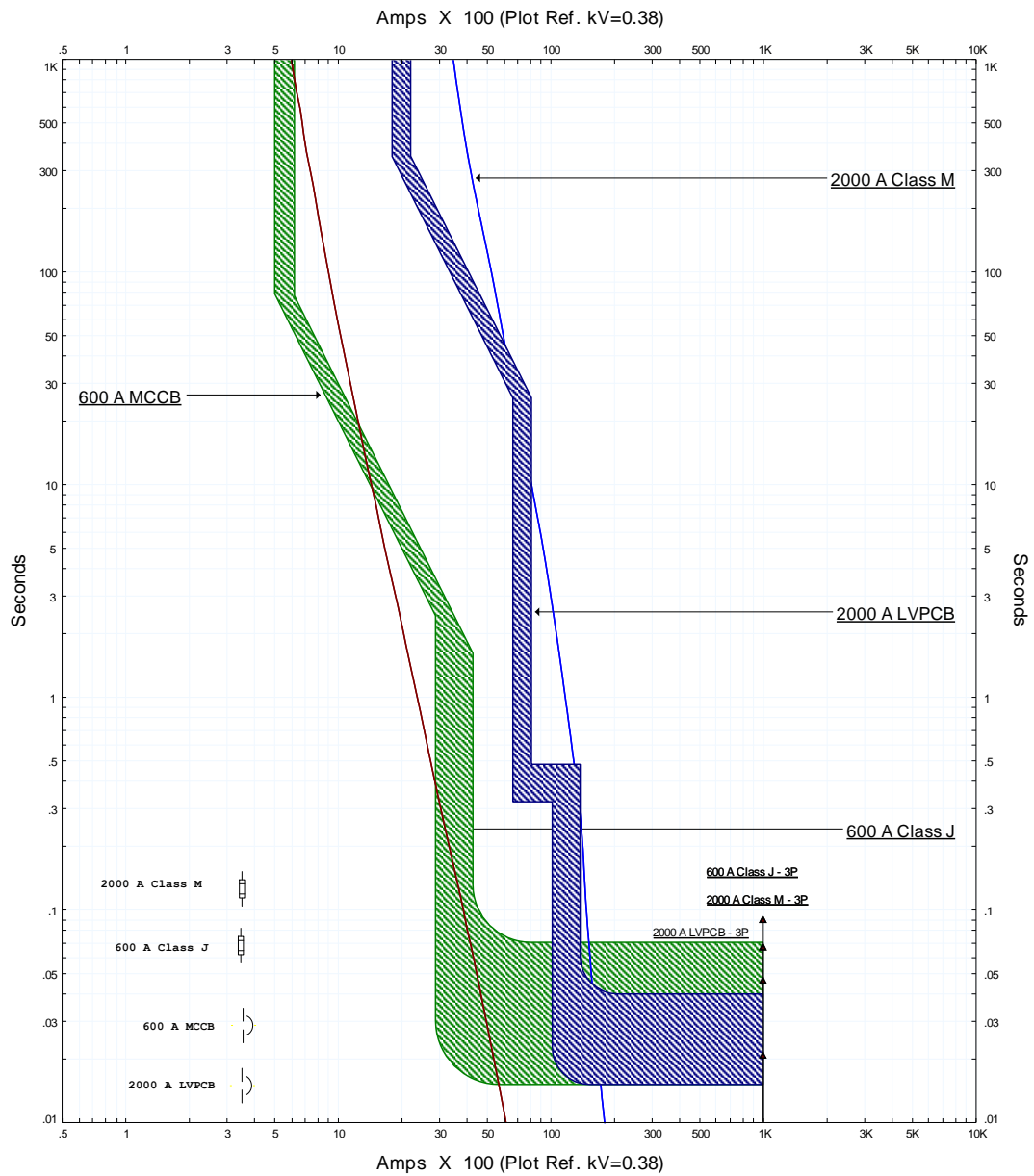

Figure 1. Time –current characteristics of four low voltage elements for assessment of device limited ratings of arc-resistance equipment

This states that as the device current ratings increase, it becomes more challenging to select and choose elements for incident energy limitation. Such devices need to have a nameplate indicating:

- Accessibility type
- Arc short-circuit current, kA rms
- Arc duration element type that controls the incident energy
- Protective element, manufacturer and part number
- Rated maximum clearing time, protective element, ms.

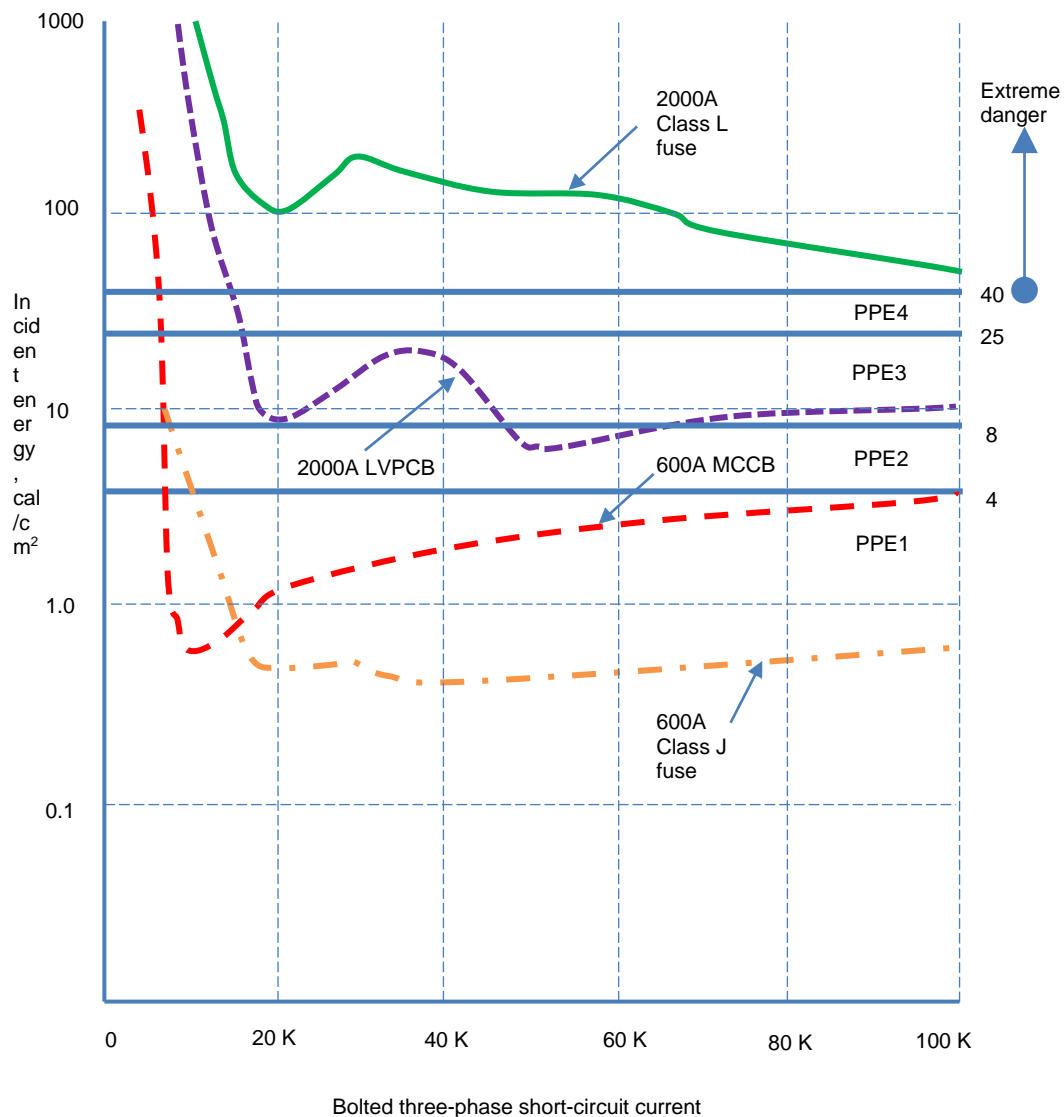

Figure 2. Computed incident energy release versus three-phase bolted short circuit current for the four elements in Figure 1

An arc-resistant device with element limited ratings could be designed without plenums to transfer the arc products away from the device, particularly for low voltage device. The equipment type is not replaceable with an “equivalent” equipment of different manufacturer, as its characteristics can differ. This can be an important limitation in application of limited arc-resistant equipment.

IMPACT of Cable Connections

When the protective element is placed some distance away and the device is cable connected, the impact of cable impedance needs to be considered. It will decrease the bolted three-phase short circuit current at the device. The effect of cable connections in low voltage systems will be more pronounced as, relatively for the same cable lengths, a higher reduction in the fault current at the equipment will happen. This demands a careful arc flash assessment.

TESTING ACCORDING TO IEEE GUIDE

The IEEE guide gives details of test configurations for all devices and details for devices covered in IEEE standards — arc initiation, current limiting elements, installation of test indicators, and test conditions — voltage, current, frequency, etc. These details are not part of this course. An interested reader may peruse the relevant IEEE standard. The evaluation of test results is shortly discussed.

Criterion 1

Adequately latched or secured doors, covers do not open. Some bowing or buckling and distortion are allowable provided no element comes as far as the position of the indicator mounting racks or walls on any accessed area. For an installation installed closer to the wall than tested, the additional considerations are:

1. The allowable distortion is less than the intended distance to the wall.
2. Exhausting gasses are not conducted to the wall.

Criterion 2

No fragmentation of container happens within the time period defined for the test, though ejection of small elements, up to an individual mass of 60 g, from any assessed external surface above a height of 2 m and from any surface not under evaluation. No limitation is put on the number of ejected elements.

Criterion 3

Burn through assessment. It is presumed that any opening in the switchgear created by direct contact with the arc will also start an indicator installed outside of switchgear at that same point. As all the area cannot be covered with indicators, any hole in the area under evaluation that results in direct contact with the arc is treated as the cause of damage. Opening above the indicator mounting rack height (2 m) that do not create ignition of horizontally installed indicators are ignored.

Accessibility Type 1 - That arcing does not create holes in the freely accessible enclosure front.

Accessibility Type 2 - That arcing does not create holes in the freely accessible enclosure front, rear and sides.

Criterion 4

No indicators trigger as a result of escaping gases. Indicators triggered as a result of burning of paint or labels, glowing elements, and so on, are excluded from this evaluation. Holes in horizontally installed indicators created by particles that do not trigger the indicator are ignored. Surface discoloration or charring that does not end in the glowing or flaming of the indicator cloth is allowed.

Criterion 5

This criterion demands that all earthing connections remain effective. The guide qualifies that all conditions and circumstances that can impact performance of devices are not addressed. Certain byproducts, like toxic gases and sound pressure — which has to be considered by the user when devices are evaluated— are not addressed. During testing, all energy release external to the device is observed using specific rack mounted indicators strategically arranged around outside surface of switchgear. Figure 3 presents a common indicator frame configuration. This supports a specific material untreated for fire retarding and 100% black cotton with a density of 150 g/m². The weave is known as Cretonne, which is a strong fabric with a cotton wrap and woven weft. Hence, it is evident that after an internal arc flash event, the arc-resistant device may need considerable maintenance before placing it back in service. The integrity of restoring the device back to pre-fault even stays uncertain. It is prudent that the manufacturer has to be contacted, and the device receives a thorough examination with replacement of parts as needed. Note that retesting at the site is not done.

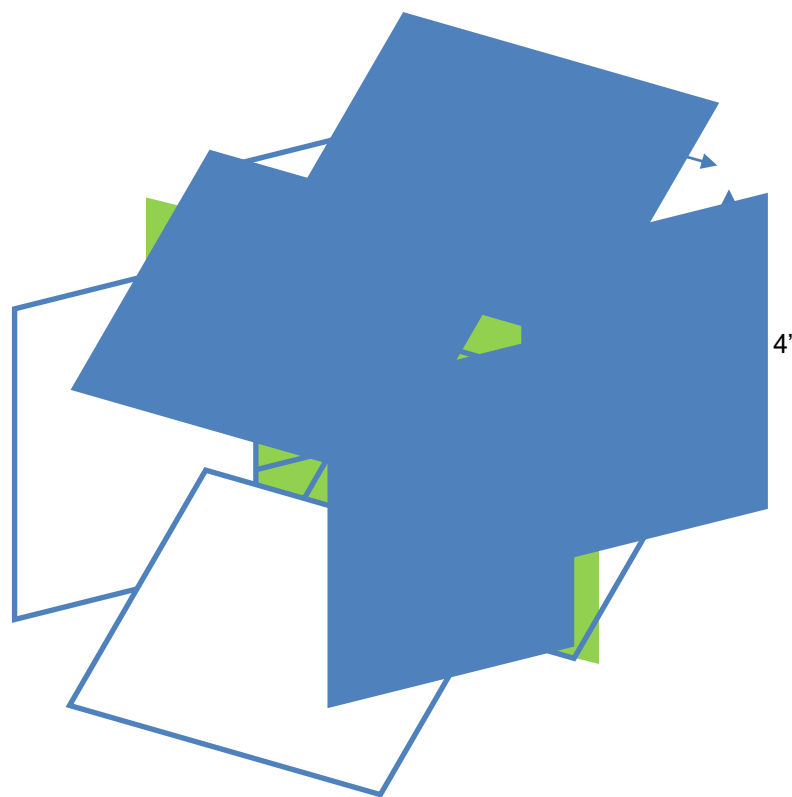

Figure 3. A common indicator frame used in arc-resistance testing

Maintenance

The manufacturer needs to identify specific features of the device and details of maintenance procedures that are needed. The device has to be maintained according to manufacturer's suggestions.

PRESSURE RELIEF

The pressure inside the container rises at a rate of 18 lbf/in²/ms. There is a starting compression stage after the arc is started. This is due to the oxygen and other materials being taken by the arc. The vaporization of these materials promptly pressurizes the container. As the pressure grows, the pressure relief element arrests its continuous rise as shown in Figure 4. At this instance, a big amount of thermal energy has been produced. The maximum pressure inside the device is a function of the used pressure relief system.

The manufacturers make a special system for pressure relief. These pressure relief devices open fast to limit the damage created by internal pressure during compression fault stage. Figure 5 presents a rupture relief plate, and Figure 6 presents hinged arc relief panels with inner shields.

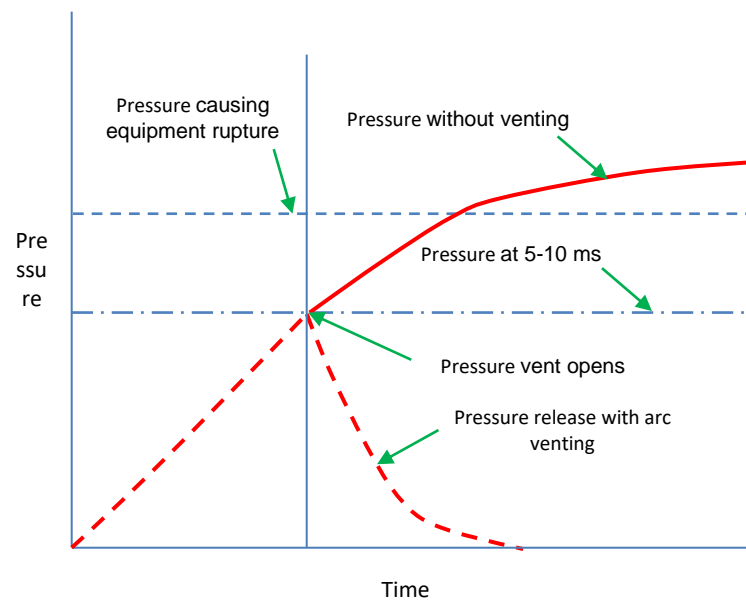

Figure 4. Pressure buildup after an arc flash event, with and without venting

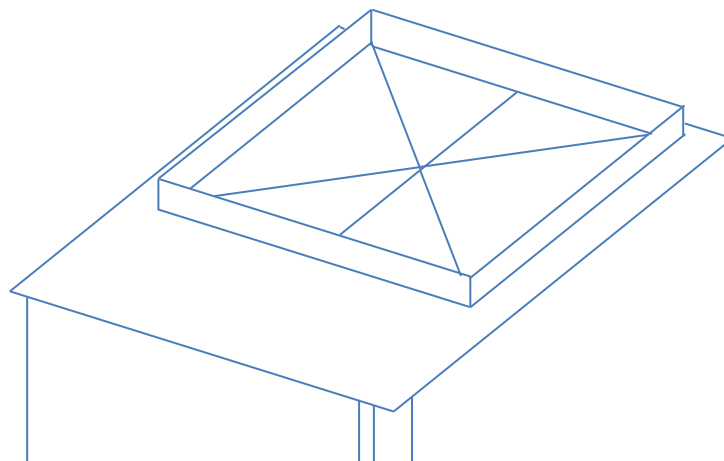

Figure 5. Flap plates on an arc-resistant device, typically closed

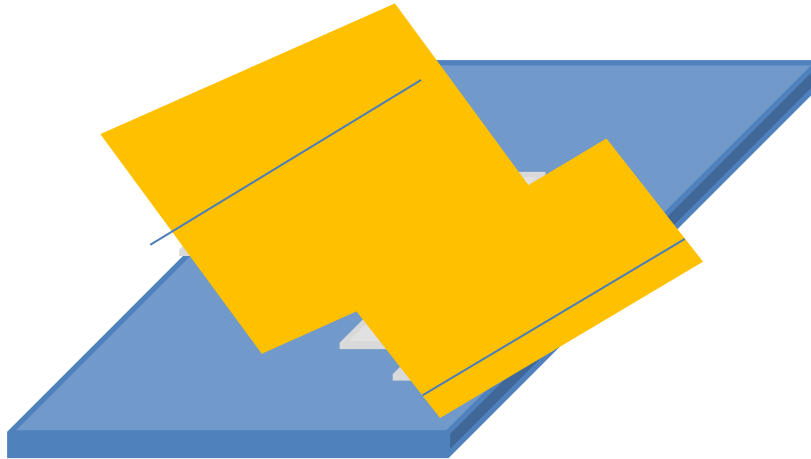

Figure 6. Hinged arc panels with inner shield

VENTING AND PLENUMS

The two possible options are:

1. Vent into the nearby area
2. Transfer the arc products outside the electrical room to a safe location

Venting into NEARBY Area

This is a typical technique to vent the gases into the area above the switchgear. No element, such as building structure, wire ways, ducts, pipes, conduits and lighting fixtures, should violate the minimum clear space suggested by the manufacturer. Minimum ceiling and wall clearances are also needed. The clear space demands are commonly much higher than the space demands with plenum installations. The other problems could be:

- The arc products are at a temperature of 16,000–35,000°F. The objects in the direct way may be instantaneously vaporized unless the arc gasses have cooled before a contact is established.
- The hot gasses could be diverted and splash down on a staff or anyone else present near the equipment.
- Considerations have to be provided to the materials placed above the container. Cables and other flammable materials could be burnt.

Also, additional considerations of building construction apply:

- Sufficient volume to absorb pressure wave
- Structural capacity to withstand pressure wave
- The ability of windows, doors and other openings to sustain pressure wave
- The ability of the ceiling, roof and fittings, placed in the path of gasses released from switchgear pressure vents, to stay intact.

Figure 7 presents arc-resistant MV container with arc chimneys. For the low voltage MCCs, plenums, ductwork, and chimneys are not typically needed to channel the arc flash products.

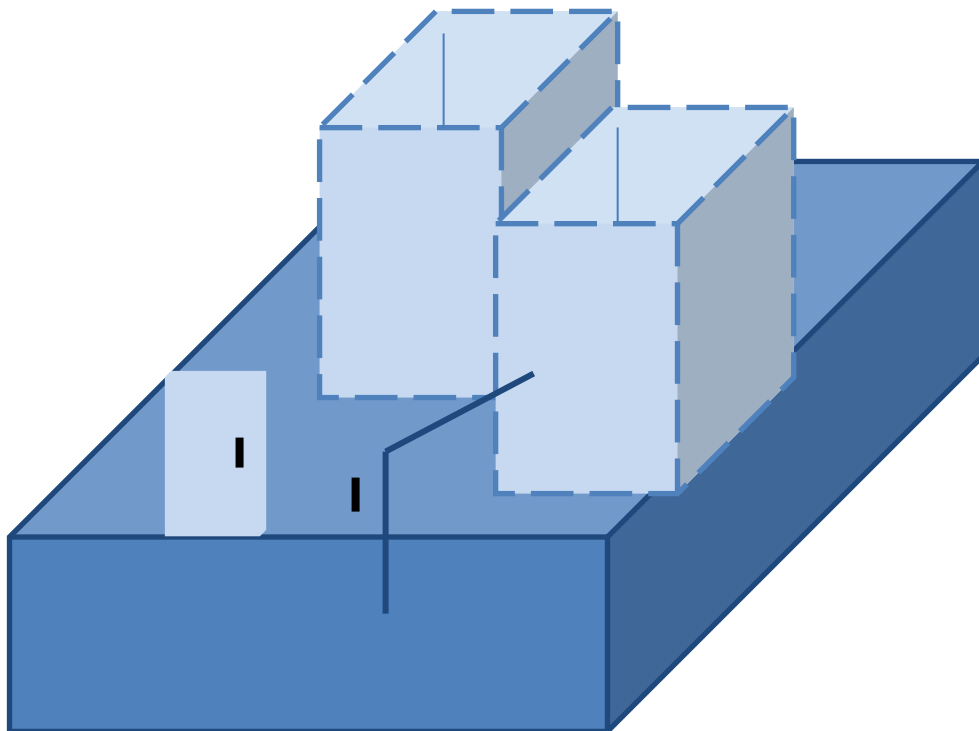

Figure 7. Common arc-resistant medium voltage container with arc chimneys

Plenums

The plenums will help the channeling of arc products to a safe and controlled area. The plenum run outside the electrical rooms and the containment location has to be in line with manufacturer's suggestions. Some considerations are:

- The release location needs to be free of inflammable materials and common traffic.
- The number of turns, bends, and lengths of plenums will be decided by the electrical room arrangement and needs to be considered in the planning stage.
- The plenums typically exhaust from the top of the device, and there need to be attachment structures to carry the weight of the plenums.
- A big number of bends in the duct may impede the venting, and the manufacturer needs to be consulted for the acceptable arrangement.
- The space on the top of the room to run the plenum needs to be evaluated.
- The exhaust duct should not allow external air to enter the switchgear compartment. If the duct goes through a wall, it may need fire rating equal to the rating of the wall. The duct needs to prevent external fires from penetrating the wall at the point where the duct goes through the wall while giving an exhaust path for the arc gases to exit. Considerations have to be applied to safeguard the nearby devices from exhaust gases and pressure waves.

Figure 8 presents common medium voltage device with top plenums. Figure 9 presents an improper arrangement of external venting.

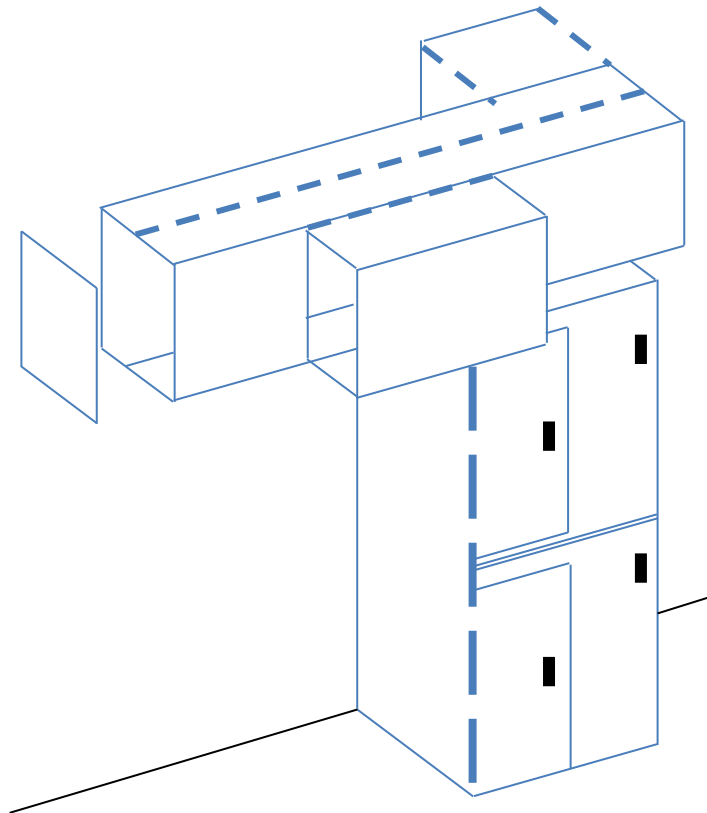

Figure 8. Common arc-resistant medium voltage container with plenum

CABLE ENTRIES

The power and control cable entries need to be sealed so that the pressure wave does not spread through conduit or cable systems. There are two sealing procedures:

- Adequate sealing putty can be applied; polyurethane foams specially made for cables and conduits can be applied.
- Optionally, there are pressure-sealing methods, which apply compression style sealing rings to seal around each conductor. There are also electrometric sealing methods which expand under high temperature to give a tight seal.

Generally, there are number of considerations that need to be addressed in proper design and application of arc-resistant devices. As an initial step, the arc-resistant device needs to be determined after system studies, calculations of arc flash currents and their duration.

Next, the electrical designs and physical installations have to coordinate. The different types of accessibilities with their suffixes give a selection suited for the special requirements. Techno-economic considerations, building designs, installations, layouts, adequate maintenance, training, and service — all enter into a well-educated decision. Moreover, it is pertinent that the specifications attached to the arc-resistance devices in IEEE guide are followed and the device is installed, operated, and maintained as per manufacturer's suggestions. Any modifications at site, without previous investigations, can end in unintended arc flash hazard or incident.

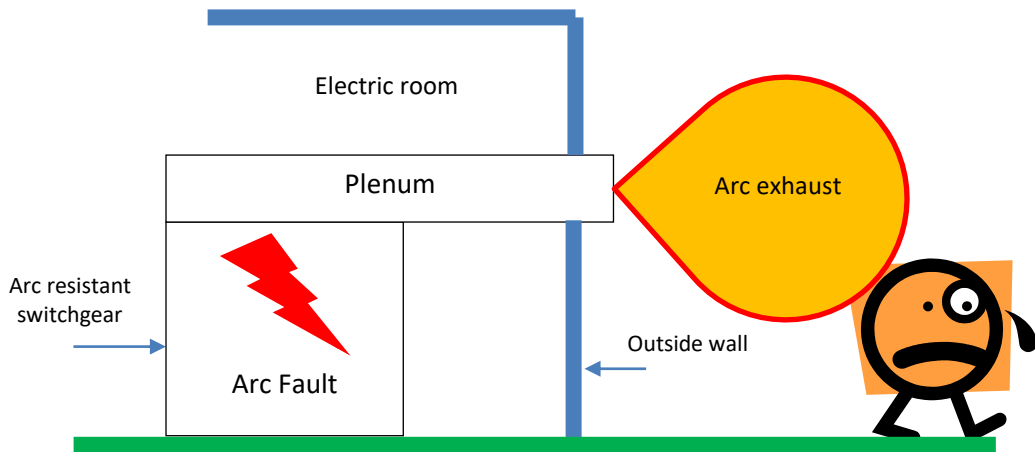

Figure 9. Inadequate arrangement of external arc venting system

Maintenance of Fire resistant Clothing

Laundering: Get complete directions on care of FR clothing from the manufacturer. Some cleaning chemicals such as chlorine bleach may impact the finish, decrease the fabric strength and take away the colour of the cloth. Some manufacturers state that the flame resistance feature is not impacted by the bleach. Follow laundering directions given by the manufacturer.

Contamination: Grease, oil, or other flammable materials catch fire quickly and will keep on burning even after the arc finishes. Hence, FR clothing polluted with these substances should not be utilized. Attention should be taken at work to annul polluting FR clothing from such materials.

Storage: The clothing should be kept in a safe condition so that it is reliable.

Useful Life of PPE

The useful life of a PPE may reckon on different elements such as the material with which it is produced, the severity of work activity and the abrasion resistance features of the PPE. Collect data from the manufacturer to decide the useful life. The useful life of a PPE is typically presented following some approximations. It must be noted that if the real circumstances are different from these approximations, then the stated expected life may not be relevant. It is best if the PPE user gets from the manufacturer, the relevant life of the PPE for the proposed application.

Table 1. Expected useful life of FR clothing - examples

Fabric	Industrial Launderings	Expected Service Life (months)
INDURA 100% Cotton	36-50	18-24
INDURA Ultra Soft 88% Cotton 12% High Tenacity Nylon	60-80	28-38

PPE Selection

PPE should be selected according to the requirements of the staff and the nature of job performed. Some of the elements are discussed below.

Comfort: It is essential that the staff is not uncomfortable. Otherwise there could be a danger of accidents happening. Comfort is vital both physically and mentally. PPE for great incident energy (hazard/risk category #4 or higher) may have thick and heavy clothing, headgear and gloves. The comfort level may vary from one individual to another. It is essential to make sure that each worker feels as comfortable as possible, wearing the PPE. Various staff may find various materials more comfortable than others. It may be useful to let the staff to try out the PPE to ensure that it is acceptable in terms of comfort. It may take some time before a staff gets used to new PPE. Hence, it is advised that the staff practice wearing the PPE before performing job on live exposed devices. This also assures that the PPE does not intervene with the task.

Fit: A loose fitting PPE gives more thermal insulation via the air trapped inside.

Nevertheless, it should not be too tight or too loose so as to intervene with the task.

Layers: As noted in the previous section, more layers give additional air insulation and higher degree of protection. Multi-layer FR clothing is also more comfortable than a single layer of thick and heavy clothing.

Materials: Selection of fabric material can impact both comfort and weight. There are various types of treated cotton and synthetic fabric available from different manufacturers. For multi-layer clothing, the staff may choose to have unprocessed flammable fabric such as cotton or wool for inner garments at lower incident energies.

Abrasion Resistance: Some FR clothing is usable with high abrasion resistance quality. Staff that completes heavy duty job need to use this kind of PPE. Clothing without such quality can be easily destroyed, and may fail to properly guard the staff from an arc flash.

FR Clothing types

Vest/Undergarment: These can be worn underneath shirts, jackets or pants. They give an extra layer of protection. Multi-layered clothing is more elastic, simple to work with and has trapped air to give extra thermal insulation. Combination of vest/undergarment with a shirt enhances the total arc rating.

Shirt/Pant: FR shirts and pants can be utilized for incident energy of 4.0 cal/cm² or below. These can be multi-layered for greater arc rating.

Bib Overall: Bib overalls worn with a shirt gives greater protection to the chest area than a shirt worn with a pant.

Coverall: Coveralls are same as shirt and pant.

Jacket: These are typically multi-layered and are like multi-layered shirts.

Hood: The hood is part of the headgear, has face protection and has FR fabric covering the head, ears, neck and shoulders.

Other PPE

Headgear: The headgear comprises of a non-conductive helmet and hood that covers the head, ears, neck and shoulders. It also has a face shield and chin cover. The face shield absorbs some of the incident energy. Nevertheless, it should not spoil visibility. Safety glasses should be worn underneath the headgear.

Gloves: Gloves give insulation from both electricity and heat. A combination of rubber (worn inside) and leather (worn outside) materials is usually utilized. The gloves should be sufficiently long to cover the sleeves.

Table 2. Voltage Classification of Gloves

Glove Voltage Classification	Maximum Working Voltage	Proof Test kV
Class 00	500	2.5
Class 0	1,000	5.0
Class 1	7,500	10
Class 2	17,000	20
Class 3	26,500	30
Class 4	36,000	40

Boots: Heavy duty shoes or boots should be worn where incident energies are greater than 4 cal/cm².

Hot Stick: Hot sticks are utilized to control fuses and switches. These give insulation from the high voltage elements. They also allow the staff to keep greater working distance, so that the incident energy is lower.

Arc Suppression Blanket: This gives a barrier from arc flash.

Ear Muffs: Arc blast can induce serious ear injuries. Ear muffs should be kept to give sound insulation and decrease the influence.

Mechanical Barriers: As noted in the previous paragraphs, mechanical barriers can give protection from thermal radiation as well as from blast pressure. They can be utilized for racking breakers, but are not suited for most other work.

Arc Flash Resistant Equipment - Quiz

Updated: 1/24/2025

1. If arc - resistant equipment is specified _____ is needed.
(A) AFD
(B) Differential protection systems
(C) All of the above
(D) None of the above
2. If any panels or doors are opened for maintenance, which are not intended to be opened, the equipment is no longer arc resistant.
(A) True
(B) False
3. NFPA 70E specifies an hazard risk category of _____ for the arc - resistant switchgear.
(A) 1
(B) 4
(C) 2
(D) 3
4. _____ equipment includes switchgear with arc - resistant designs and features at the freely accessible front of the equipment only.
(A) Type 1
(B) Type 2
(C) Suffix B
(D) Suffix C
5. _____ presents equipment where normal operation involves opening the doors or cover of the compartments.
(A) Type 1
(B) Type 2
(C) Suffix B
(D) Suffix C
6. _____ equipment includes switchgear with arc - resistant designs and features at the freely accessible exterior (front back and sides) of the equipment only.
(A) Type 1
(B) Type 2
(C) Suffix B
(D) Suffix C

7. _____ lays down that the arcing does not cause holes in the freely accessible front of the enclosure or in the walls isolating the low voltage control or instrument compartments.
- (A) Suffix 1B
 - (B) Suffix C
 - (C) Suffix 2B
 - (D) Suffix 1B
8. Arcing does not cause holes in the freely accessible front, sides, and rear of the enclosure for _____ equipment.
- (A) Accessibility Type 2
 - (B) Accessibility Type 1
 - (C) All of the above
 - (D) None of the above
9. For an installation mounted closer to the wall than tested _____.
- (A) The permissible distortion is less than the intended distance to the wall
 - (B) Exhausting gasses are not directed to the wall
 - (C) All of the above
 - (D) None of the above
10. _____ lays down that the arcing does not cause holes in the freely accessible front, sides, and rear of the enclosure or in the walls isolating the low voltage control or instrument compartments.
- (A) Suffix 1B
 - (B) Suffix C
 - (C) Suffix 2B
 - (D) Suffix 1B
11. Special PPE is required for the presence of a worker in the vicinity of the arc - resistant equipment.
- (A) True
 - (B) False
12. _____ suffix is designated for equipment where isolation from effects of an internal fault is desired between all adjacent compartments within a switchgear assembly.
- (A) Suffix 1B
 - (B) Suffix C
 - (C) Suffix 2B
 - (D) Suffix 1B
13. IEEE _____ requires that all grounding connections remain effective.
- (A) Criterion 1
 - (B) Criterion 2
 - (C) Criterion 3
 - (D) Criterion 5

14. _____ designation is not applicable to equipment using open bus or open frame construction.
- (A) Suffix 1B
 - (B) Suffix C
 - (C) Suffix 2B
 - (D) Suffix 1B
15. When the protective device is located some distance away and the equipment is cable connected, the effect of _____ should be considered.
- (A) Cable capacitance
 - (B) Cable rating
 - (C) Cable resistance
 - (D) Cable impedance
16. The _____ implies that the arcing does not cause holes in freely accessible front of the enclosure or in the walls separating the compartments in which arc is initiated from all adjacent compartments.
- (A) Suffix 1C
 - (B) Suffix 2C
 - (C) Suffix 1B
 - (D) Suffix 2B
17. The _____ implies that the arcing does not cause holes in the freely accessible front, sides, and rear of the enclosure or in the walls separating the compartments in which arc is initiated from all adjacent compartments.
- (A) Suffix 1C
 - (B) Suffix 2C
 - (C) Suffix 1B
 - (D) Suffix 2B
18. The _____ is designated for equipment designed for installations where some external surfaces of equipment are inaccessible.
- (A) Suffix 1C
 - (B) Suffix 2C
 - (C) Suffix 1B
 - (D) Suffix D
19. Arcing does not cause holes in the freely accessible front of the enclosure for _____ equipment.
- (A) Accessibility Type 2
 - (B) Accessibility Type 1
 - (C) All of the above
 - (D) None of the above
20. Sealing of the cable entries can be done with _____.
- (A) Polyurethane foams
 - (B) Compression style sealing rings
 - (C) All of the above
 - (D) None of the above